

INTRODUCTION

The AVC63-12 and AVC125-10 regulate the level of excitation supplied to the field of a conventional, brushless, synchronous generator.

Regulation is achieved by sensing the generator output voltage, converting it to a dc signal, and comparing the signal to a reference voltage. An error signal is developed and used to control the dc field power in order to maintain a constant generator output.

Each regulator includes frequency compensation with selectable slope, inverse-time overexcitation shutdown, buildup circuitry, single- or three-phase voltage sensing, single- or three-phase shunt or permanent magnet generator (PMG) power input, parallel droop compensation, and an accessory input. The accessory input provides compatibility with devices such as var/power factor controllers or excitation limiters.

SPECIFICATIONS

Power Input *

Configuration: 1-phase or 3-phase
Frequency: 50 to 400 Hz

Voltage Range

AVC63-12: 90 to 153 Vac
AVC125-10: 180 to 264 Vac

Maximum Continuous Burden

AVC63-12: 1,092 VA
AVC125-10: 1,750 VA

* See *Options* for Inrush Current Reduction Module information.

Sensing Input

Configuration: 1-phase or 3-phase
Burden: <1 VA per phase

Voltage Range

Option A: 90 to 139 Vac
Option B: 180 to 264 Vac

Nominal Frequency

Option 1: 50 or 60 Hz
Option 2: 400 Hz

(See Table 2 for style/option information.)

Accessory Input

Voltage Range: ± 3 Vdc

Power Output

Maximum Continuous Output

AVC63-12: 12 Adc at 63 Vdc
AVC125-10: 10 Adc at 125 Vdc

10 Second Forcing Output

AVC63-12: 24 Adc at 125 Vdc
AVC125-10: 20 Adc at 250 Vdc

Minimum Field Resistance

AVC63-12: 5.25 Ω
AVC125-10: 12.5 Ω

Regulation Accuracy

$\pm 0.5\%$ of voltage setpoint, average response

Voltage Drift

$\pm 0.5\%$ variation for a 40°C (104°F) change

Response Time

<4 ms

Frequency Compensation

One or two jumper-selectable V/Hz curves with knee frequency adjustable from 45 to 65 Hz (50/60 Hz units) or 300 to 430 Hz (400 Hz units). Refer to Figure 1 (60 Hz) and Figure 2 (400 Hz) for sensing models.

EMI Suppression

Internal filter. (See *CE Conformity*)

Voltage Buildup

Automatic voltage buildup occurs from residual generator voltage as low as 6 Vac (AVC63-12) or 12 Vac (AVC125-10).

Overexcitation Shutdown

Overexcitation shutdown protection reduces the output voltage to zero in the times shown below for the listed voltages. Other voltages and times are based on the inverse time characteristic curves of Figures 3 and 4

AVC63-12
125 Vdc, $\pm 10\%$ in approximately 10 s
210 Vdc, $\pm 10\%$ in approximately 1 s or less
AVC125-10
250 Vdc, $\pm 10\%$ in approximately 10 s
370 Vdc, $\pm 10\%$ in approximately 1 s or less

Droop/Line Drop Compensation

<10 VA adjustable from 0 to 10% of rated input current at 0.8 power factor. (LDC compensates only for voltage drop due to line reactance and reactive components of the load current.)

Agency Approvals

UL Recognition

Standard 508, File E97035

CSA Certification

Standard CAN/CSA-C22.2 No. 14-95,
File LR 23131

CE Conformity

Radiated Emissions
EN50081-2
Conducted Emissions
EN50081-2 (EN55011, Class A)
Conducted Emissions
EN50081-2 (EN55011, Class A)
ESD Immunity
EN50082-2 (4 kV contact, 8 kV air)
EFT Immunity
EN50082-2 (2 kV coupling clamp)

Magnetic Immunity
 EN50082-2 (30 Arms, 50 Hz)
 Safety
 EN61010-1
 Radiated Immunity
 Electric Field: EN61000-4-3 (10 V/m)
 Conducted: EN61000-4-6 (10 Vrms)

Type Tests

Shock
 Withstands 20 G in each of 3 mutually perpendicular planes.

Vibration
 Withstands 4.5 G at 18 to 2,000 Hz

Physical

Temperature
 Operating: -40 to 70°C (-40 to 158°F)
 Storage: -40 to 70°C (-40 to 158°F)
 Max. Humidity: 95%, non-condensing
 Weight: 1.1 kg (2.5 lb)

INSTALLATION

Regulators are contained in an encapsulated plastic case and may be mounted in any convenient position. A regulator may be mounted directly on a genset using UNF ¼-20 or equivalent hardware. Hardware selection should be based on any expected shipping/transportation and operating conditions. The torque applied to the mounting hardware should not exceed 65 in-lb (7.34 N•m). See Figure 5 for regulator dimensions.

CONNECTIONS

Before connecting the voltage regulator into your system, review the terminal descriptions listed in Table 1 and the connection diagrams in Figures 6 through 8.

Table 1. Terminal Descriptions

| | Term # | Description |
|----------------------|--------|---|
| Upper Terminal Strip | CH GND | Chassis ground connection |
| | 2 | Auxiliary input from SCP250 and/or EL 200 (See Fig. 7) |
| | 3 | |
| | 4 | Internal voltage adjust: connect to 7. External voltage adjust: no connection |
| | 5 | 1 A current transformer (CT)* |
| | 5a | 5 A CT* |
| | 6 | CT common connection |
| | 6a | Common connection for selectable features |
| | 7 | Internal voltage adjust: connect to 4. External voltage adjust: connect to 6a |
| | 8 | Connect to 6a to select 1 V/Hz underfrequency slope |
| Lower Term. Strip | 9 | Connect to 6a to select 3-phase sensing |
| | 20 | C-phase sensing input |
| | 22 | A-phase sensing input |
| | 24 | B-phase sensing input |
| | 26 | 1- or 3-phase power input |
| | 28 | 3-phase power input |
| | 30 | 1- or 3-phase power input |
| | F1 | Field + connection |
| | F2 | Field - connection |

* The secondary winding of a sensing transformer must be grounded as closely to the transformer as practical. When interconnecting more than one transformer, ensure that the secondary winding of only one transformer is grounded.

ADJUSTMENTS

AVC63-12 and AVC125-10 adjustments are described in the following paragraphs.

Field Flashing

When the regulator is operated with the generator for the first time, the residual magnetism may not be of sufficient magnitude or the correct polarity. If the generator residual voltage is less than 6 Vac for the AVC63-12 or 12 Vac for the AVC125-10 at terminals 26, 28 and/or 30, shut down the prime mover and proceed with the following steps.

CAUTION

Do not flash the field when the generator is in motion. Regulator damage may result.

1. With the prime mover at rest, apply an ungrounded dc source of not more than 24 Vdc to terminals F1 (+) and F2 (-) in series with a limiting resistor. Use 1 Ω of resistance for each volt applied. The power source should have a rating of at least 1 W/Ω.
 EXAMPLE: If using a 24 Vdc source, use a 24 Ω, 24 W resistor.
2. Allow the field to be flashed for approximately 10 seconds before removing the dc source.
3. If voltage buildup does not occur after performing steps 1 and 2, verify the polarity of the dc source and repeat steps 1 and 2.

Frequency Roll-Off (UF KNEE)

The underfrequency knee (roll-off) is typically set below the nominal system frequency. When the generator speed falls below the knee setpoint of the regulator, generator voltage is reduced proportionally to the speed of the machine. To adjust the underfrequency knee, perform the following steps.

1. Adjust the generator frequency at the nominal level (50, 60, or 400 Hz).
2. Adjust the UF KNEE control counter-clockwise.
3. Adjust the VLT ADJ control for nominal generator voltage.
4. Adjust the UF KNEE control clockwise until the voltage begins to decrease.
5. Adjust the UF KNEE counter-clockwise until the voltage just returns to the value set in step 3.

The underfrequency knee is now set just below the nominal operating frequency. Further rotation in the counter-clockwise direction will lower the knee frequency setpoint at which underfrequency compensation just begins.

Connecting a jumper from terminal 8 to 6a will provide an underfrequency slope of 1 PU V/Hz. No connection to terminal 8 will result in an underfrequency slope of 2 PU V/Hz. The slope can also be selected on the 400 Hz models. However, the actual V/Hz curve is approximately 1 PU or 2 PU, depending if terminal 8 is jumpered to 6a.

Stability (STB)

An oscilloscope or other voltage recording device should be used in an optimal stability setting is desired. Adjust the stability setting with the generator at no load.

Clockwise rotation of the STB control will slow response time. Counter-clockwise rotation will speed response time. If

rotated too far counter-clockwise, the generator voltage may oscillate (hunt).

To obtain good response, rotate the STB control counter-clockwise until the system just begins to oscillate. Then, rotate the control clockwise just past the point where oscillation occurred. Apply various amounts of load to determine proper stability performance.

Voltage (VLT ADJ)

Installation of a jumper across terminals 4 and 7 enables the front-panel VLT ADJ control to vary the generator nominal voltage over the operating range.

To allow operation of an external voltage adjust control, remove the jumper between terminals 4 and 7 and connect a 10 k Ω , external potentiometer across terminals 6a and 7. The front-panel VLT ADJ control should be set fully clockwise for proper operation of the external adjustment. Note that as the external potentiometer resistance increases, generator voltage also increases.

Factory Calibration (FAC CAL)

CAUTION

The FAC CAL control is intended for use during factory calibration only. The following procedure can be used if the factory calibration has been disturbed.

1. With the regulator operating on a generator, adjust the FAC CAL control fully counter-clockwise and the external voltage adjust control fully clockwise.
2. Adjust the FAC CAL control clockwise until the generator voltage reaches the desired maximum voltage setting. The regulator is calibrated and the FAC CAL control can be sealed.

Parallel Droop Compensation

Variable parallel droop compensation levels can be obtained by adjusting the DRP control. Clockwise rotation increases the amount of droop for a given condition.

Line Drop Compensation

When the sensing input CT connections are reversed to provide line drop compensation, the droop adjustment become the line drop compensation adjustment.

STARTUP

Startup and troubleshooting procedures for the AVC63-12 and AVC125-10 are listed in the following procedure. Symptoms of startup problems stemming from improper regulator adjustments and certain generator system problems that resemble faulty regulation are listed with possible solutions. Simplifying the system by eliminating components, such as remote adjustment potentiometers and other nonessential items, can be helpful in the troubleshooting process. Adjustments, options, and an operational test are included in the paragraphs following the procedure.

1. Ensure that the regulator has been installed in accordance with the *Installation* and *Connections* paragraphs before proceeding with system startup.
2. Start the prime mover and bring it up to rated speed.

If the voltage does not build up:

- a) Flash the field.

- b) Remove power for one minute to reset the overexcitation circuit.

3. Slowly adjust the VOLT potentiometer or external, voltage adjust rheostat until the voltage reaches nominal.

If the voltage will not build up to rated:

Check the generator output for a shorted or excessive load.

4. Apply and remove the generator load to check stability. If the generator response is too slow or is hunting (oscillating):

- a) Check the generator output for a shorted or excessive load. Adjust the STB potentiometer with no load applied.

- b) Check stability of the governor.

5. Check regulation under normal operating conditions.

If the regulation is poor:

- a) Check that the prime mover is up to rated speed.
- b) Check that the voltmeter is connected at the same point as the regulator sensing.
- c) Use an average-sensing voltmeter (not an rms-sensing voltmeter).

6. Reduce the generator frequency. The generator output should decrease from this point.

If the generator output voltage does not decrease at the desired frequency:

- a) Check that all wiring is in accordance with the connection diagrams provided in this instruction sheet.
- b) Adjust the UF KNEE control.

OPTIONS

The AVC63-12 and AVC125-10 may be equipped with the following options to enhance operation.

Remote Voltage Adjust

Connect a 10 k Ω , 2 W potentiometer across terminals 6a and 7, remove the jumper from terminals 4 and 7, and adjust the front panel VLT ADJ control fully clockwise to enable remote adjustment of the voltage setpoint.

Inrush Current Reduction Module

A Basler ICRM-15 is required when energizing the AVC63-12 or AVC125-10 from a source that is already at the regulator input power rating. The ICRM-15 minimizes the amount of inrush current that could be seen when power is applied.

Excitation Disable

This option disables excitation by removing power from the regulator. A switch removing voltage from terminals 26, 28 and/or 30 will remove regulator power.

Excitation Limiter

The Basler EL 200 provides an initial, fast-acting limit of the field current at a user-defined level. Once the field current has changed to the selected level, the EL 200 provides a signal to the regulator to change the excitation level.

Var/Power Factor Control

This option enables the AVC63-12 and AVC125-10 to regulate the var and power factor while the generator is connected to an infinite or utility bus. The Basler SCP 250

| | | | | |
|----------------------------------|----------------------|---------------------|----------------------|-----------------------|
| Publication 9337200991 | Revision F | Instructions | Date 03/12 | Page 3 of 6 |
|----------------------------------|----------------------|---------------------|----------------------|-----------------------|

supplies a dc signal into terminals 2 and 3 of the regulator to correct for vars or power factor. Figure 7 illustrates regulator and SCP 250 interconnection.

Current Boost System

With the CBS 212 option, if the generator output voltage decreases below the preset operating point due to a short or large motor starting, the CBS 212 provides full current boost to the generator exciter until the voltage returns to a level just above the operating point.

Manual Voltage Control

The Basler MVC-112 provides a method for manually controlling the generator output during generator startup and commissioning or in the unlikely event of a regulator failure. Model MVC-112 is suitable for use with either the AVC63-12 or AVC125-10 voltage regulator.

OPERATIONAL TEST

This test verifies the operation of all eight models of the AVC63-12 and AVC125-10. Table 2 lists each regulator model and the corresponding test voltage and frequency.

Table 2. Testing Parameters

| Model | Power | Input Sensing | |
|-------------|-------|---------------|-------|
| | | Vac | Hz |
| | | AVC63-12A1 | 120 |
| AVC63-12A2 | 120 | 400 | |
| AVC63-12B1 | 120 | 240 | 50/60 |
| AVC63-12B2 | 120 | 240 | 400 |
| AVC125-10A1 | 240 | 120 | 50/60 |
| AVC125-10A2 | 240 | 120 | 400 |
| AVC125-10B1 | 240 | 240 | 50/60 |
| AVC125-10B2 | 240 | 240 | 400 |

- To test regulator operation, perform the following steps.
1. Connect the regulator according to Figure 9 and apply the appropriate voltages.
 2. Adjust the VLT ADJ control fully counter-clockwise. Observe that the lamp is off.
 3. Adjust the VLT ADJ control clockwise. Observe that the lamp turns on.
 4. Adjust the VLT ADJ control until the lamp just turns off. Regulator operation is satisfactory if the above results are obtained. However, stability must be tested with the generator and regulator in operation.

MAINTENANCE

A periodic inspection of the regulator should be made to ensure that it is clean and free from accumulations of dust and moisture. Ensure that all connections are clean and tight.

TROUBLESHOOTING

In case of regulator failure or defective operation, simplifying the system by eliminating components such as remote adjust potentiometers and other non-essential items can be helpful in the troubleshooting process.

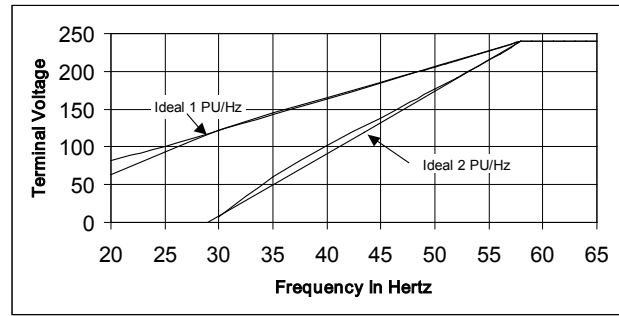

Figure 1. 60 Hz Frequency Compensation

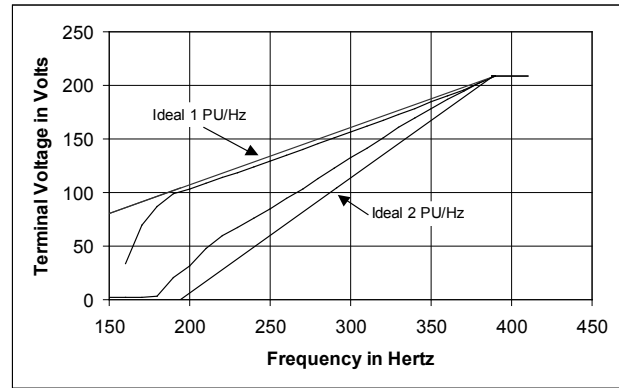

Figure 2. 400 Hz Frequency Compensation

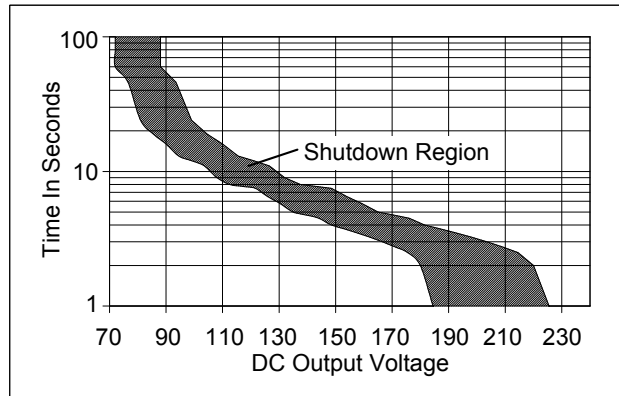

Figure 3. AVC63-12 Overexcitation Shutdown Characteristics

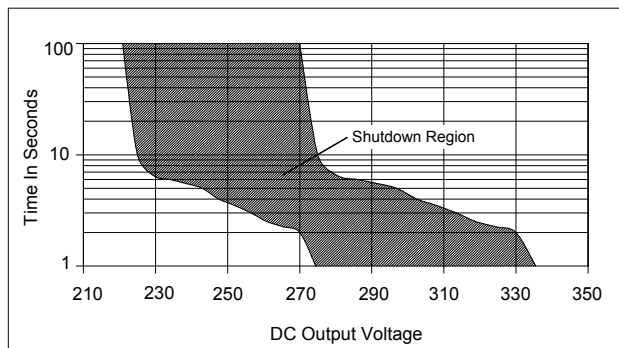

Figure 4. AVC125-10 Overexcitation Shutdown Characteristics

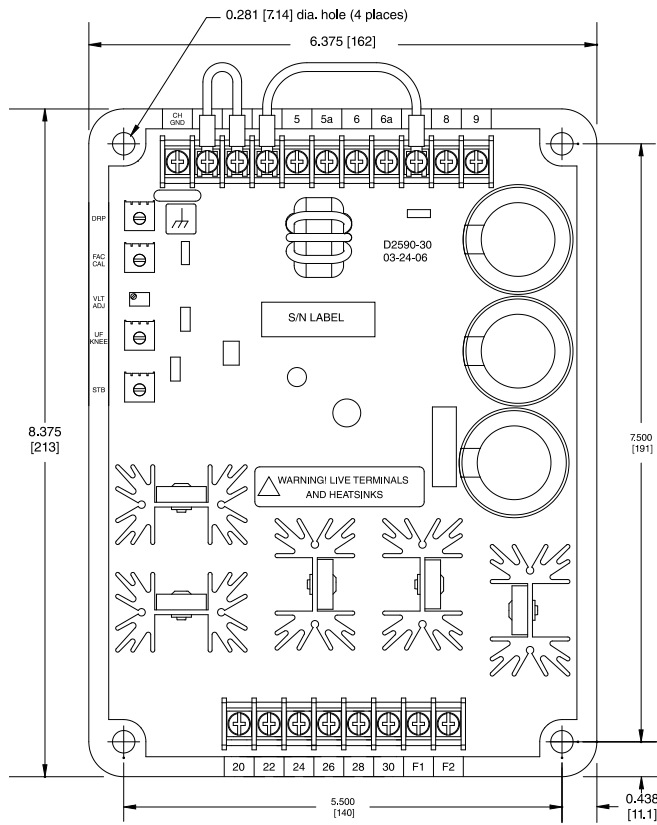
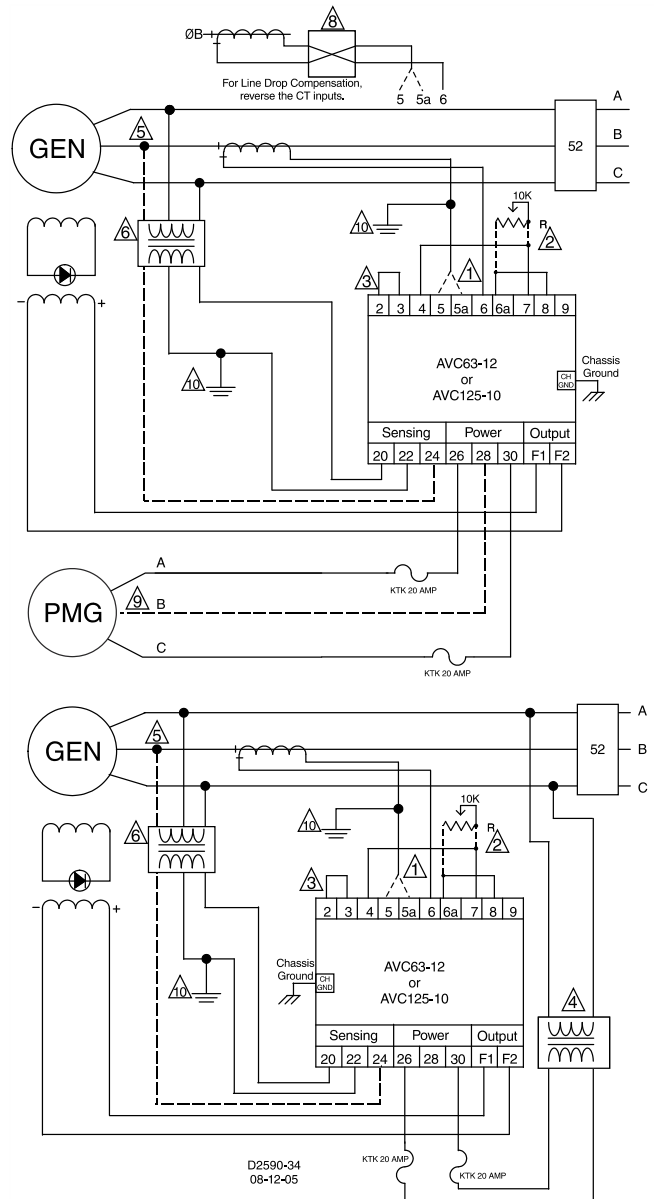
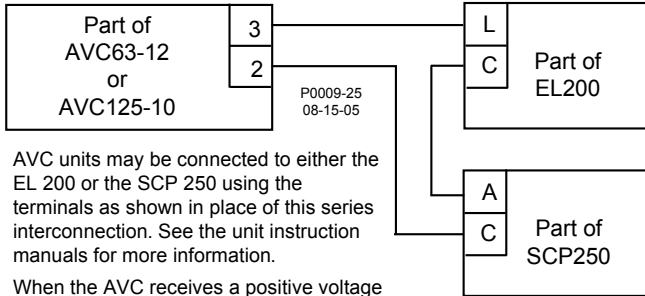

Figure 5. Outline Drawing



- ⚠ Connect to terminal 5 for 1A CT. Connect to terminal 5a for 5 A CT. Also reference Note 10.
- ⚠ Connect remote voltage adjust from 6a to 7, remove link 4-7 if fitted with a remote adjust. Connect 6a to 8 for 1 V/Hz, remove for 2 V/Hz underfrequency slope. Connect 6a to 9 for 3-phase sensing, open for 1-phase sensing.
- ⚠ Connect 2 and 3 to SCP 250 and EL 200 as shown in Figure 7. Short when not used.
- ⚠ Power step-down transformer required if generator voltage does not match the regulator input power range.
- ⚠ Required for 3-phase sensing. Also reference Note 2.
- ⚠ Sensing step-down transformer required if generator voltage does not match the sensing voltage range identified by the voltage regulator model number.
- 7 ABC rotation shown.
- ⚠ LDC compensates for voltage drop due to line reactance and reactive components of the load current only.
- ⚠ Shown with 3-phase PMG. For 1-phase PMG, omit B-phase connection to terminal 28.
- ⚠ The secondary winding of a sensing transformer must be grounded as closely to the transformer as practical. When interconnecting more than one transformer, ensure that the secondary winding of only one transformer is grounded.

Figure 6. Typical Interconnection Diagram



AVC units may be connected to either the EL 200 or the SCP 250 using the terminals as shown in place of this series interconnection. See the unit instruction manuals for more information.

When the AVC receives a positive voltage (terminal 2 positive, terminal 3 negative) at the Accessory input, the setpoint decreases. A negative voltage (terminal 2 negative, terminal 3 positive) at the Accessory input increases the setpoint.

Figure 7. AVC Interconnection Diagram

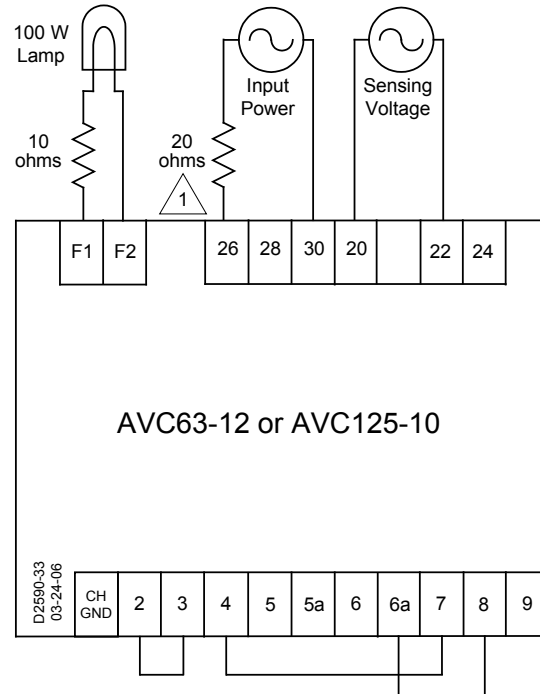

1 A wire-wound resistor with a minimum power rating of 15 W should be used.

Figure 9. Operation Test Setup

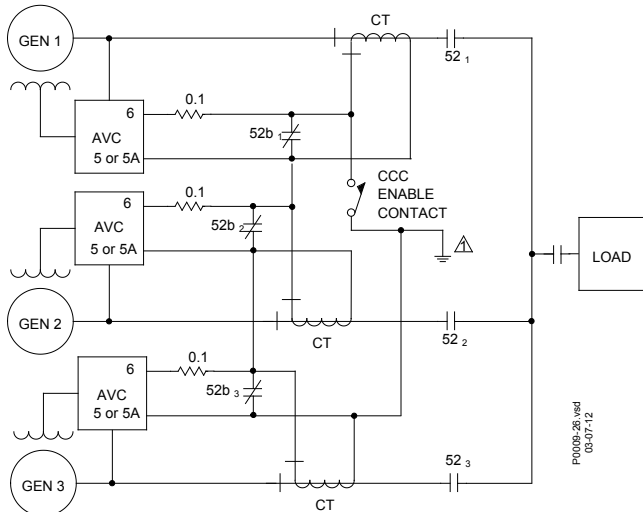

⚠ The secondary winding of a sensing transformer must be grounded as closely to the transformer as practical. When interconnecting more than one transformer, ensure that the secondary winding of only one transformer is grounded.

Figure 8. Cross-Current Compensation