

SMAVC6307 VOLTAGE REGULATOR

Using enhanced technology, the SMAVC6307 half wave voltage regulator is designed for use on 50/60 Hz brushless generators. This encapsulated regulator is small in size, ruggedly constructed, and incorporates solid state technology with frequency compensation, automatic voltage build-up, and parallel droop as standard.

FEATURES

- Integrated circuitry for compact size, simplicity, high reliability.
- Extremely rugged.
- Exciter field current 7A continuous, 11.5A forcing.
- Regulation accuracy better than $\pm .25\%$ no load to full load.
- Fast response.
- Frequency compensation.
- Overexcitation shutdown.
- Built-in parallel droop compensation.
- EMI suppression.
- Available from stock.
- CSA certified.
- Qualified to the requirements of:
 - IEEE C37.90.1 for Surge Withstand Capability.
 - ASTM B117-73, Method 711-1C, for Salt Fog.

**FEATURES AND
APPLICATIONS**
this page

**DESCRIPTION AND
SPECIFICATIONS**
pages 2 &4

**INTERCONNECT
DRAWING**
page 3&4

DIMENSIONS
page 4

DESCRIPTION

The SMAVC6307 model of voltage regulator maintains generator line voltage on brushless generators from 100kW to over 500kW in size. The voltage regulator senses generator average voltage to maintain a precise regulation band within ± 2.5 percent. This is accomplished by converting a 240 Vac single phase power input to a controlled DC signal to the generator's exciter field. The solid-state voltage build-up circuit will enable automatic generator

line voltage build-up with a voltage input to the regulator of at least 6 Vac. Customer accessible stability, underfrequency and range adjusts enable fine tuning of the voltage regulator to the generator in use.

Figure 1 demonstrates the underfrequency characteristics of the voltage regulator during prime mover low speed conditions. Customer curve selection matches the voltage regulator to 50 or 60 Hz systems.

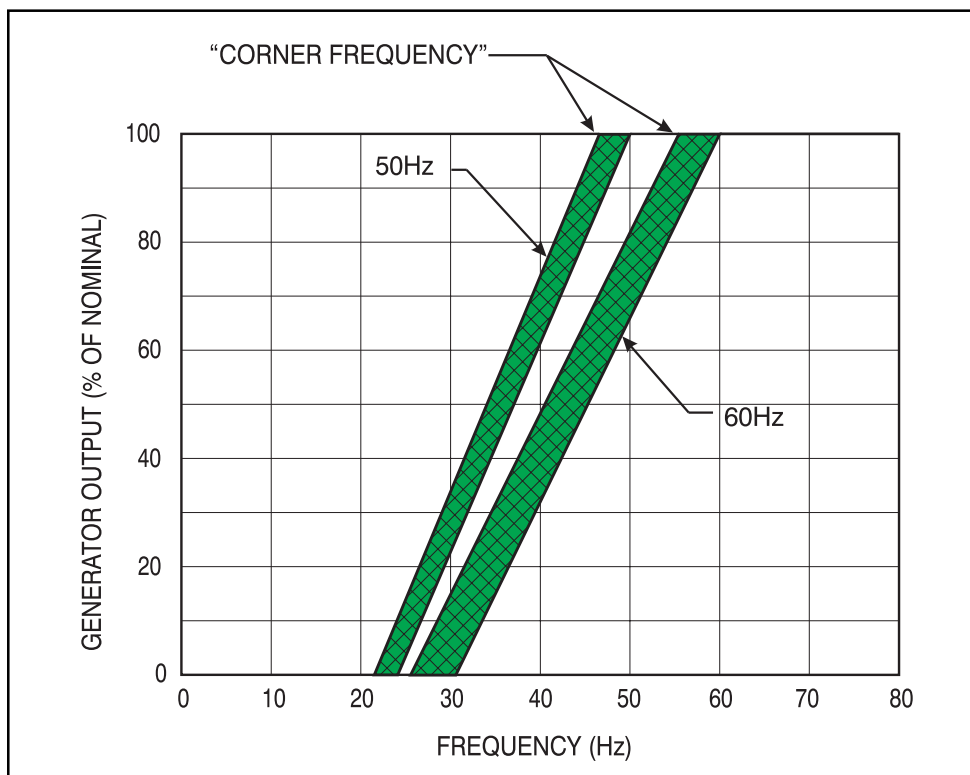

Figure 1 - Frequency Compensation Characteristic

SPECIFICATIONS

DC OUTPUT				EXCITER FIELD RESISTANCE		POWER INPUT		SENSING INPUT	
MAX. CONT.		MAX. FORCING 10 SEC. (120 Vac INPUT)		MIN. OHMS @ 25°C	MAX. OHMS	SINGLE PHASE VOLTAGE RANGE	BURDEN	VOLTAGE ADJUST RANGE	BURDEN
AMP	VOLT	AMP	VOLT						
7	63	11.5	105	9.0	100	190-277Vac $\pm 10\%$	900VA	190-240Vac $\pm 10\%$	<5VA

SPECIFICATIONS (continued)

DC OUTPUT POWER: 7 Adc at 63 Vdc maximum continuous, 11.5 Adc at 105 Vdc ten second forcing. (Forcing with 240 Vac nominal input).

EXCITER FIELD DC RESISTANCE: 9.0 ohms minimum; 100 ohms maximum.

AC POWER INPUT: Operating range: 190-277 Vac single phase, 50/60 Hz $\pm 10\%$. Burden 900VA.

SENSING INPUT: 190-240 Vac single phase, 50/60Hz $\pm 10\%$. Burden <5VA.

VOLTAGE ADJUST RANGE: 170-264 Vac.

REGULATION ACCURACY: Better than $\pm .25\%$ no load to full load.

RESPONSE TIME: Less than 1.5 cycles for $\pm 5\%$ change in sensing voltage.

EMI SUPPRESSION: Internal electromagnetic interference filtering.

PARALLEL COMPENSATION: 5A input from a current transformer with 10VA burden @ 0.8PF.

VOLTAGE BUILDUP: Internal provisions for automatic voltage buildup from generator residual voltages as low as 6 Vac.

TERMINATIONS: 1/4 "Fast-On" Terminals.

POWER DISSIPATION: 35 Watts maximum.

OPERATING TEMPERATURE: -40°C (-13°F) to $+60^{\circ}\text{C}$ ($+140^{\circ}\text{F}$).

STORAGE TEMPERATURE: -40°C (-40°F) to $+85^{\circ}\text{C}$ ($+185^{\circ}\text{F}$).

VIBRATION: Withstands 1.2 Gs at 5 to 26 Hz; 0.036" double amplitude at 27 to 52 Hz; and 5 Gs at 53 to 1000 Hz.

SHOCK: Withstands up to 15 Gs in each of three mutually perpendicular axes.

WEIGHT: 10 oz. (0.28 kg) Net.

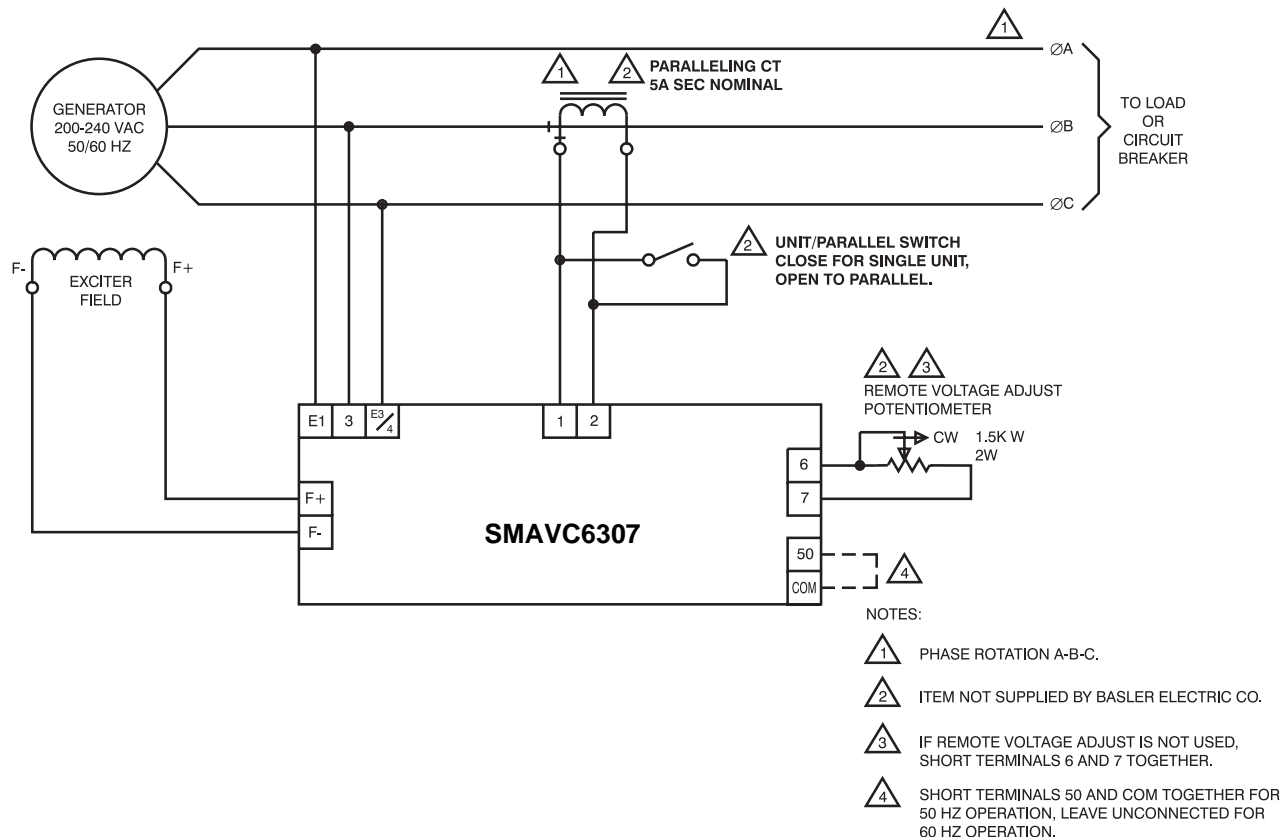
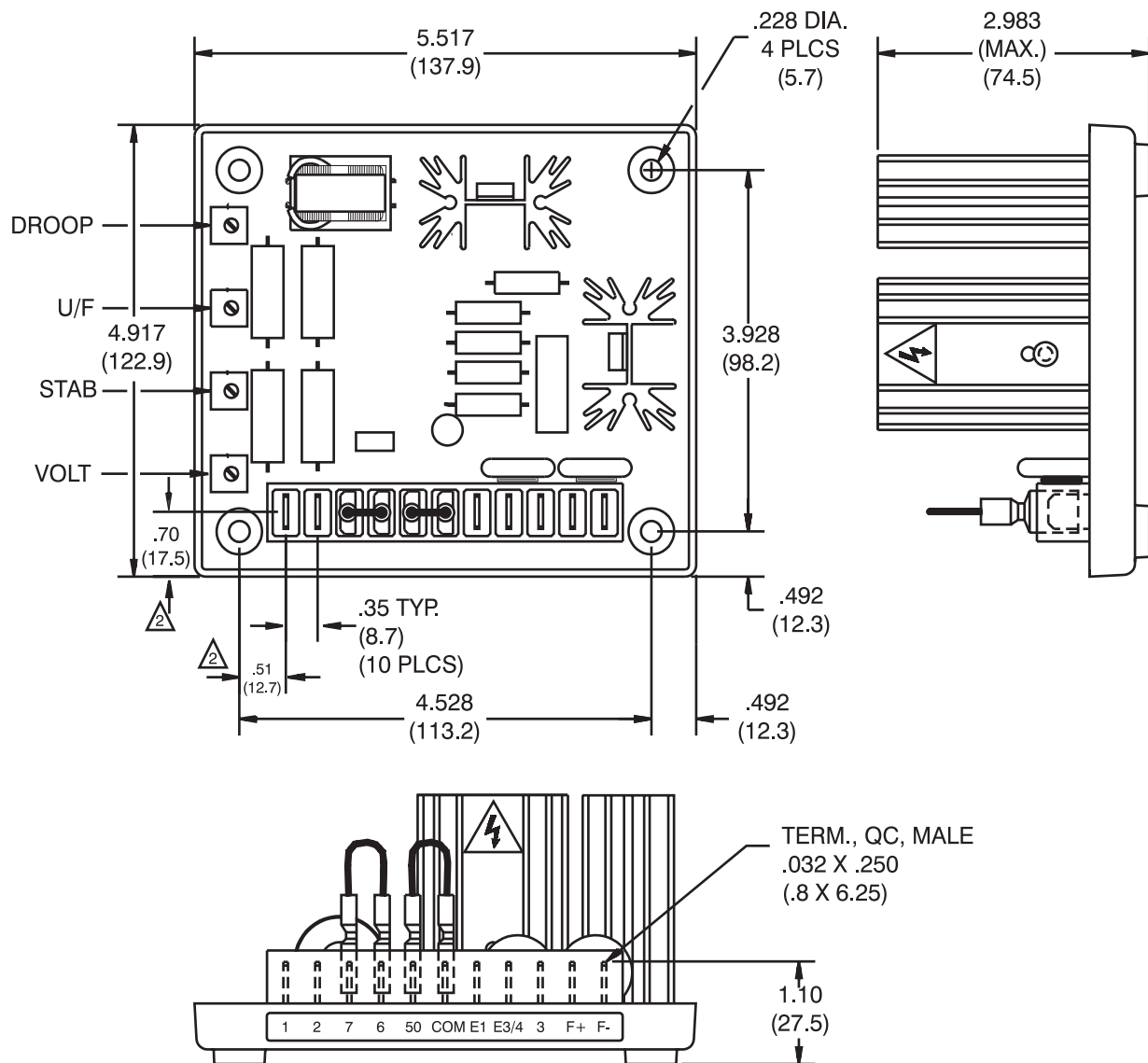

Figure 2 - Typical Interconnection Diagram



NOTES:

- 1) DIMENSIONS ARE IN INCHES (MILLIMETERS).
- 2) DIMENSIONS TO TERMINALS ARE APPROXIMATE.
- 3) NET WEIGHT = 1 LB. 1 OZ.
- 4) WATTS DISSIPATED = 35 MAX.

Figure 3 - Outline Drawing