

AUTOMATIC VOLTAGE REGULATOR R630 AREP/PMG

Installation and maintenance

**AVR
MODEL R630 / PMG**

TABLE OF CONTENT

AVR CONSTITUTION	PAGE : 2
GENERAL DESCRIPTION : NT1950000 /a	PAGE : 3
CARDS DESCRIPTION : NT1950xxx	PAGE : 11
START-UP : NT1959000 /a	PAGE : 44

NOTE

**THE ELECTRICAL CONNECTION DIAGRAM ARE ONLY GIVEN
AS AN INDICATION. PLEASE REFER TO THE SPECIFIC DIAGRAMS
OF YOUR ALTERNATOR**

WARNING

**TO PREVENT PERSONNAL INJURY OR EQUIPMENT DAMAGE,
ONLY QUALIFIED TECHNICIANS/OPERATORS SHOULD
INSTALL AND OPERATE THIS DEVICE**

CAUTION

**MEGGERS AND HIGH POTENTIAL TEST EQUIPMENT MUST NOT BE
USED. INCORRECT USED OF SUCH EQUIPMENT COULD
DAMAGE THE SEMICONDUCTORS CONTAINED IN THE AVR**

AVR MODEL R630 / PMG

CONSTITUTIVE ELEMENTS

DESIGNATION	N° printed circuit board	N° complete card	N° instruction manual	REMARKS		
Wired empty rack		C51950250	NT1950000/c-02/95	SHUNT (+booster)		
Wired empty rack		C51950251	NT1950001/b-10/94	PMG		
Complete Generator I/O board		C51950200	NT1950010/b-10/94	100 / 120V - 50 / 60Hz		
Complete Generator I/O board		C51950202	NT1950010/b-10/94	400 / 450V - 50 / 60Hz		
3F Complete Mains I/O board		C51950220	NT1950020/b-10/94	100 / 120V - 50 / 60Hz		
3F Complete Mains I/O board		C51950222	NT1950020/b-10/94	400 / 450V - 50 / 60Hz		
2F Complete Mains I/O board		C51950210				
1F Complete Interface board		C51950215				
Rack supply	CP1950040	C51950041	NT1950040/a-11/92			
Sensing	CP1950050	C51950051	NT1950050/a-11/92			
PID, limitation	CP1950060	C51950061	NT1950060/a-11/92			
Driver	CP1950070	C51950071	NT1950070/b-11/93			
CosØ, KVAR	CP1950080	C51950081	NT1950080/b-10/94			
Limit Istator	CP1950090	C51950091	NT1950090/a-11/92			
Manual mode 1	CP1950100	C51950101	NT1950100/a-02/93			
Digital U / P.F potentiometer	CP1950110	C51950111	NT1950110/a-01/94			
Digital Ified pot and Follower	CP1950115	C51950141	NT1950115/a-01/94			
Mains P.F régulation	CP1950120	C51950121	NT1950120/a-04/94			
Rotating diode fault detector	CP1950130	C51950131	NT1950130/a-06/96	Available June 1996		
<table border="1" style="width: 100%; border-collapse: collapse;"> <tr> <td style="padding: 5px;">= Necessary</td> </tr> <tr> <td style="padding: 5px;">= Optionals</td> </tr> </table>					= Necessary	= Optionals
= Necessary						
= Optionals						

IMPORTANT : The informations given by this sheet must be used to order spare parts. Take care of it

AVR MODEL R630 / PMG

GENERAL DESCRIPTION

1) APPLICATION

- The AVR model R630 can be used with brushless self-excited type generators, "SHUNT", "SHUNT with BOOSTER" or "SHUNT with PMG" excitation. In case of "SHUNT with BOOSTER" the booster current is totally monitored by the AVR.
- The AVR is able to insure, depending of its constitution, solo operation, parallel operation between equivalent generators or parallel operation with the mains with $\cos\phi$ or KVAR regulation.

2) DESCRIPTION

- The AVR model R630 is composed of electronic cards which are included in a rack 19".
- Except the necessary "Generator I/O", the optional "mains I/O" located on the left of the rack and the "driver" card located on the right, all the other cards can be plugged anywhere in the rack. Future optional cards could be added without any internal wiring modification.
- The rear flat cable (BUS 64 points) is given more long as it can be connected to an optional interface terminal block which gives all the internal test points or in the future the possibility to connect another rack if the cards number will become too important.

3) INTERCONNECTIONS

- External interconnections are located on the top of the rack in form of two terminal blocks:
- A power / voltage terminal block (19 terminals, two or three through fuses or breaker)
- A command / control terminal block (41 terminals)
- A conventional wiring connects these terminal blocks to the power block fitted on a heatsink and also to the "generator I/O" and "mains I/O" to give an interface with the flat cable BUS 64 points.
- In the same manner a 8 points connector connects directly the driver card to the power block.

4) OPTIONAL CARDS

- $\cos\phi$ / KVAR regulation (2F)
- Voltage equalization with the mains (3F)
- Voltage and P.F digital potentiometers
- Manual operation
- Ifield digital potentiometer with follower
- Istator limitation
- Mains P.F or KVAR regulation from 4-20mA sensor

5) SPECIFICATIONS :

- Sensing voltage
 - : 100/110Vac 50Hz
 - : 120/130Vac 60Hz
 - : 380/420Vac 50Hz
 - : 430/450Vac 60Hz
- Power supply
 - : Depend of generator (Adaptation by PMG).
 - Single phase : Maximum 180Vac 150Hz
 - Three phases : Maximum 150Vac 150Hz
- Field output
 - : 12 Amperes nominal, 24Amp maximum during 10s on 6Ω minimum
- Accuracy
 - : +/-1% of the means of the three phases on linear load and without droop
- Voltage setting range
 - : +/-10% of the nominal voltage by means of external optional potentiometer .
- Droop setting range
 - : - 7% of the nominal voltage at $\cos\phi = 0$
- Under-frequency protection
 - : Adjustable threshold and slope from V/Hz to 2V/Hz
- Field ceiling
 - : 110% of I_f nominal permanently, unlocked in case of voltage decrease
- Protection
 - : Heatsink overheating, exciter short-circuit
- Alarm output
 - : Heatsink overheating, ceiling unlocked time too long
- Environnement
 - : Maximum ambient temperature -10°C à +50°C
 - : Fitting in control panel without excessive vibrations

6) SCHEMATICS AND DRAWINGS

- Following schematics give all the usual informations on the interconnections between the terminal block, the I/O connectors and the power block.

AVR MODEL R630 / PMG

GENERAL DESCRIPTION

MIMIC DIAGRAM EXCITATION - REGULATION

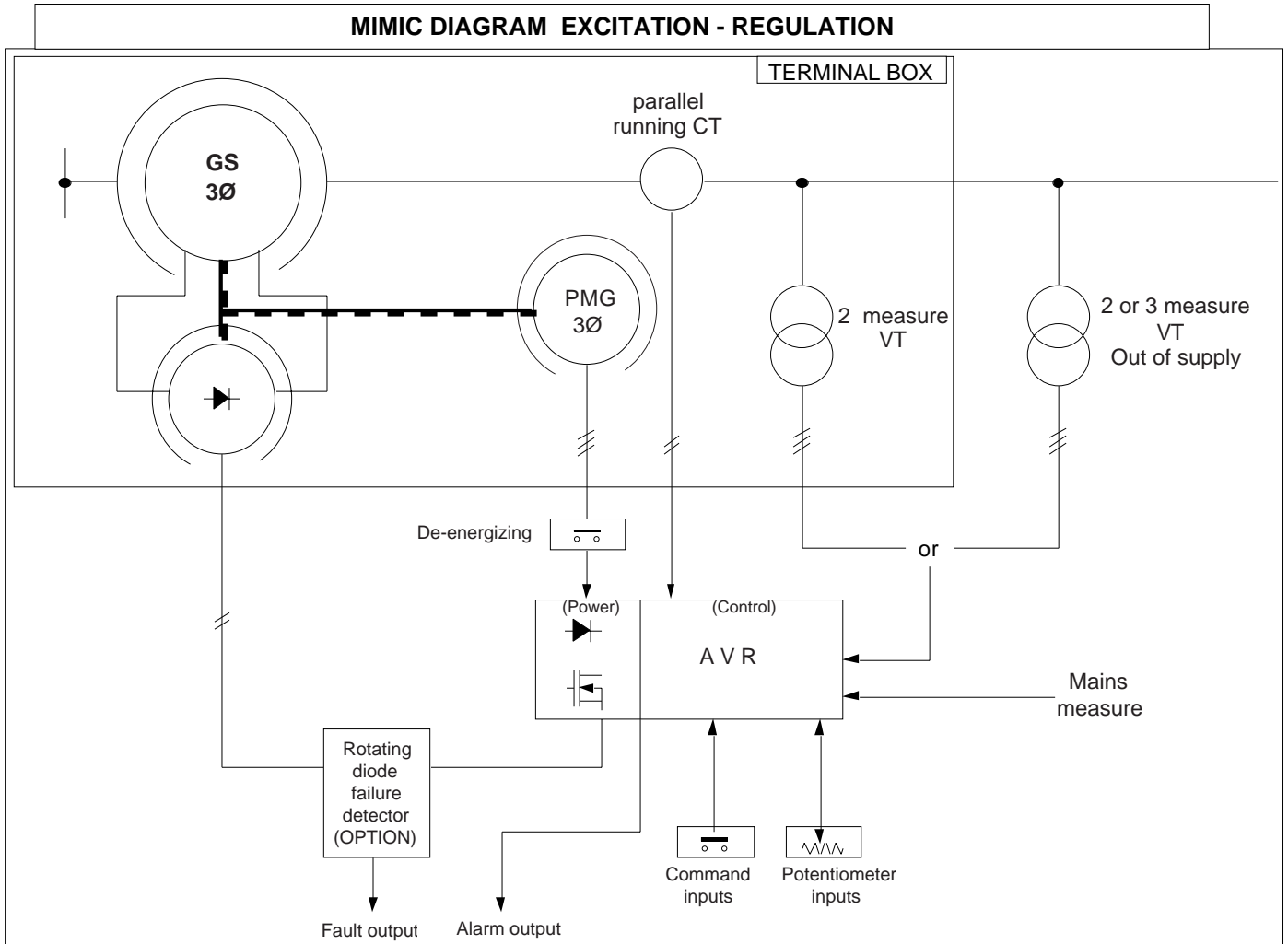

VOLTAGE / POWER TERMINAL BLOCK

1	2	3	4	5	6	7	8	9	10	11	12	13	14	15	16	17	18	19
U MACHINE	V MACHINE	W MACHINE		+ Field	- Field		// CT	// CT			U MAINS	V MAINS	W MAINS	Auxiliary supply	Auxiliary supply	PMG input fused)	PMG input fused)	PMG input fused)

COMMAND / CONTROL TERMINAL BLOCK

20	21	22	23	24	25	26	27	28	29	30	31	32	33	34	35	36	37	38	39	40	41	42	43	44	45	46	47	48	49	50	51	52	53	54	55	56	57	58	59	60
SHIELDS	VOLTAGE POT	VOLTAGE POT	VOLTAGE POT	VOLTAGE CMD	Measure If	Measure If	COSØ POT	COSØ POT	COSØ POT	KVAR POT	KVAR POT	KVAR POT	COSØ CMD	COSØ CMD	U/U CMD	U/U CMD	ALARM	ALARM	ALARM	+ 24Vdc ext	- 24Vdc ext	+U CMD	-U CMD	Commun	+lexc CMD	-lexc CMD	Auto / Manu	Auto / Manu	Info Auto / Manu	Info Auto / Manu	Ifield Pot	Manual pot	COSØ / KVAR CMD	Réserve	Réserve	Réserve	Réserve	Réserve	Réserve	Réserve

AVR MODEL R630 / PMG

GENERAL DESCRIPTION

TERM N°	VOLTAGE / POWER TERMINAL BLOCK	0F	1F	2F	3F
1	Phase 1 (U) machine (measure)	N	N	N	N
2	Phase 2 (V) machine (measure)	N	N	N	N
3	Phase 3 (W) machine (measure)	N	N	N	N
4					
5	+ field output	N	N	N	N
6	- field output	N	N	N	N
7					
8					
9	Paralleling CT phase 2 (V) S1		N	N	N
10	Paralleling CT phase 2 (V) S2		N	N	N
11	Not connected				
12	Phase 1 (U) mains (measure)				N
13	Phase 2 (V) mains (measure)				N
14	Phase 3 (W) mains (measure)				N
15	Auxiliary supply input	N	N	N	N
16	Auxiliary supply input	N	N	N	N
17	PMG power supply input (through fuse or breaker)	N	N	N	N
18	PMG power supply input (through fuse or breaker)	N	N	N	N
19	PMG power supply input (through fuse or breaker)	N	N	N	N
	COMMAND / CONTROL TERMINAL BLOCK				
20,20,20	Potentiometer shield (3 terminals)	O	O	O	O
21	External voltage potentiometer maximum CW)	O	O	O	O
22	External voltage potentiometer (cursor)	O	O	O	O
23	External voltage potentiometer (minimum CCW)	O	O	O	O
24	External voltage input (0-10Vdc, 0V to shield)	O	O	O	O
25	Fied current measurement output (+Vdc)	O	O	O	O
26	Fied current measurement output (0V)	O	O	O	O
27	External cosØ potentiometer maximum CW)			O	O
28	External cosØ potentiometer (cursor)			O	O
29	External cosØ potentiometer (minimum CCW)			O	O
30	External KVAR potentiometer maximum CW)			O	O
31	External KVAR potentiometer (cursor)			O	O
32	External KVAR potentiometer (minimum CCW)			O	O
33	cosØ regulation command input			N	N
34	cosØ regulation command input			N	N
35	Voltage equalization command input				N
36	Voltage equalization command input				N
37	Overheating or ceiling unlocked time alarm (common)	O	O	O	O
38	Overheating or ceiling unlocked time alarm output (NC)	O	O	O	O
39	Overheating or ceiling unlocked time alarm output (NO)	O	O	O	O
40	External +24Vdc supply input (relay locking)	O	O	O	O
41	External 24Vdc supply input (relay locking) common	O	O	O	O
42	Upper command voltage and P.F	O	O	O	O
43	Lower command voltage and P.F	O	O	O	O
44	Common	O	O	O	O
45	Upper command lfield (manu)	O	O	O	O
46	Lower command lfield (manu)	O	O	O	O
47	"AUTO / MANU" command input (Open = "AUTO")	O	O	O	O
48	"AUTO / MANU" command input (Open = "AUTO")	O	O	O	O
49	"AUTO / MANU" image output	O	O	O	O
50	"AUTO / MANU" image output	O	O	O	O
51	lfield direct manual setting potentiometer	O	O	O	O
52	Manual mode 1 card lfield setting potentiometer	O	O	O	O
53	CosØ / KVAR selection command input			O	O
54	Reserve				
55	Reserve				
56	Reserve				
57	Reserve				
	O = Optional N = Necessary Nothing = Not applicable			O = Optional N = Necessary Nothing = Not applicable	

AVR MODEL R630 / PMG

GENERAL DESCRIPTION

POWER TERMINALS

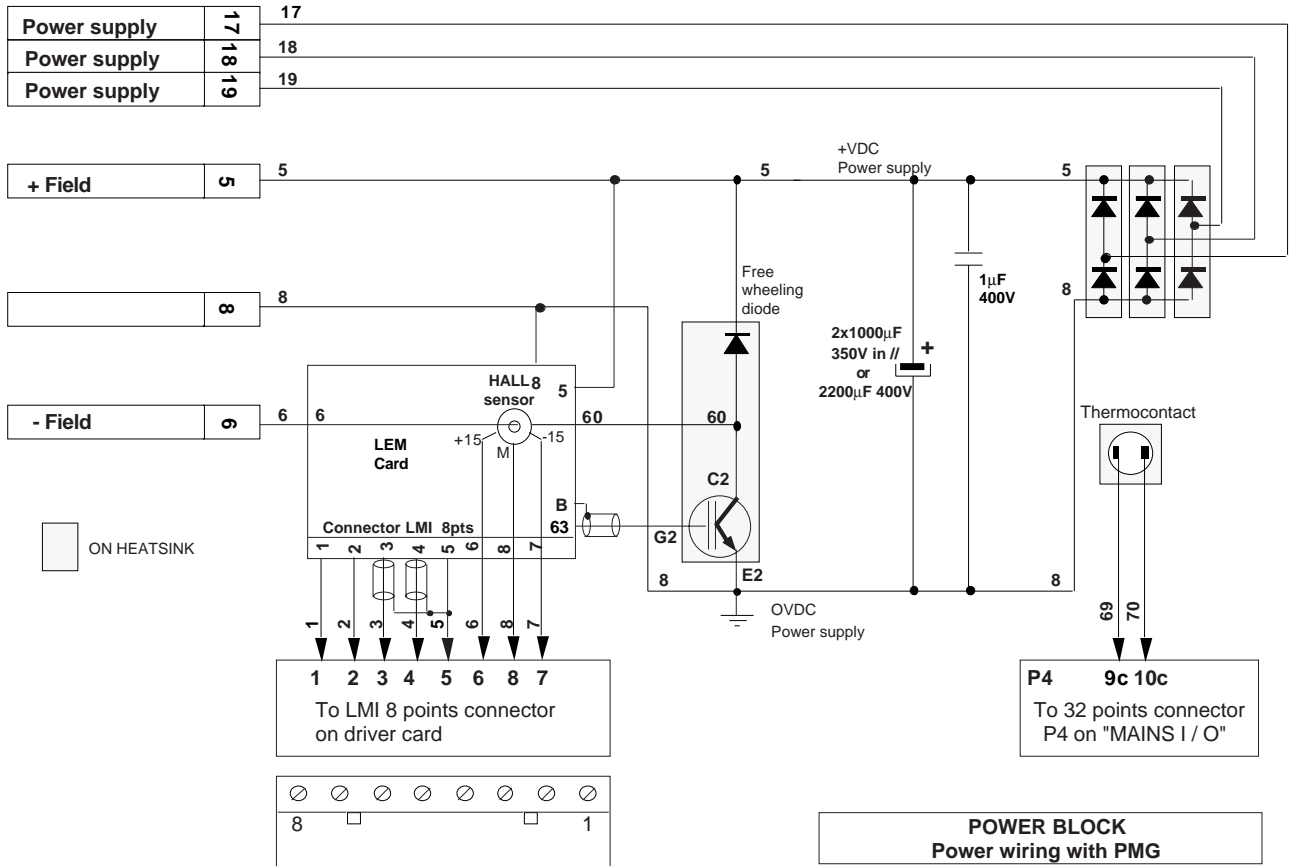

POWER BLOCK
Power wiring with PMG

Connectors wiring 32pts

POWER TERMINALS

U MACHINE	1
V MACHINE	2
W MACHINE	3
// CT	4
// CT	9
// CT	10
Auxiliary supply	11
Auxiliary supply	15
Auxiliary supply	16

CONTROL TERMINALS

SHIELDS	20	21	10c
VOLTAGE POT	22	7a	
VOLTAGE POT	22	3c	
VOLTAGE POT	23	6c	
VOLTAGE CMD	24	3a	
Measure If	25	4a	
Measure If	26	10c	
COSØ POT	27	5c	
COSØ POT	28	8a	
COSØ POT	29	6a	
KVAR POT	30	12a	
KVAR POT	31	4c	
KVAR POT	32	5a	
COSØ CMD	33	14a	
COSØ CMD	34	2c	
ALARM	37	7c	
ALARM	38	9a	
ALARM	39	10a	

J1 bac Generator I/O

15c
13c
11c
14c
13a
2c
12c
8c
15a
2c
9c
11a

CONTROL TERMINALS

+ 24Vdc ext	40
- 24Vdc ext	41
+U CMD	42
-U CMD	43
Commun	44
+If CMD	45
-If CMD	46
Auto / Manu	47
Auto / Manu	48
Info Auto / Manu	49
Info Auto / Manu	50

POWER TERMINALS

U MAINS	12
V MAINS	13
W MAINS	14

CONTROL TERMINALS

Ifield POT	51
Manual POT	52
COSØ / KVAR	53
U/U CMD	36
U/U CMD	35
RESERVE	54
RESERVE	55
RESERVE	56
RESERVE	57
RESERVE	58
RESERVE	59
RESERVE	60
RESERVE	61

AVR MODEL R630 / PMG

GENERAL DESCRIPTION

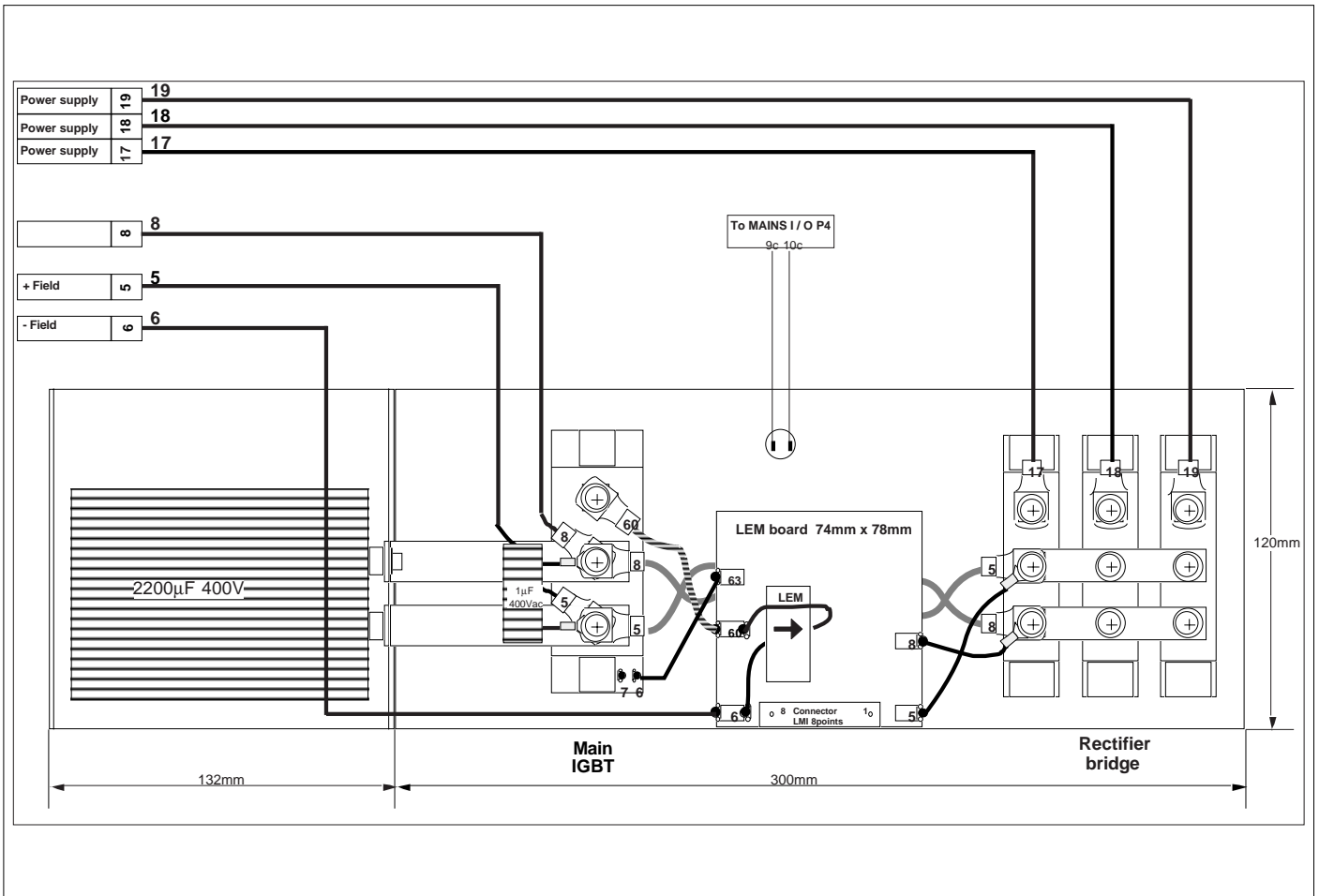

- The following tables give interconnections between each card and the 64 points flat cable.
- Grey cases give signals origine .
- Other cases where they go.
- On the left we have two numbers :
 - First the connector numbering
 - Second test block terminal number.
- On the right we have a recapitulative of all the informations wich can be found on the test terminal block.

AVR MODEL R630 / PMG

GENERAL DESCRIPTION

PIN	PIN	Gen I/O	Mains I/O	Supply	Sensing	PID, limit	CosØ, KVAR	Pot digital U	Pot digital lexc	Manu mode	Driver	test output
1c	1	+Vcc	+Vcc	+Vcc	+Vcc	+Vcc	+Vcc	+Vcc	+Vcc	+Vcc	+Vcc	+Vcc
1a	2	+Vcc	+Vcc	+Vcc	+Vcc	+Vcc	+Vcc	+Vcc	+Vcc	+Vcc	+Vcc	+Vcc
2c	3	+Vdc alim		+Vdc alim								+Vdc alim
2a	4	+Vdc alim		+Vdc alim								+Vdc alim
3c	5	-Vdc alim		-Vdc alim								-Vdc alim
3a	6	-Vdc alim		-Vdc alim								-Vdc alim
4c	7	Vac puiss 1								Vac puiss 1	Vac puiss 1	Vac puiss 1
4a	8	Vac puiss 2								Vac puiss 2	Vac puiss 2	Vac puiss 2
5c	9	GND	GND	GND	GND	GND	GND	GND	GND	GND	GND	GND
5a	10		Vac-dr1									Vac-dr1
6c	11		Vac-dr2									Vac-dr2
6a	12		Vac-dr3									Vac-dr3
7c	13	GND	GND	GND	GND	GND	GND	GND	GND	GND	GND	GND
7a	14	Vac-dm1			Vac-dm1							Vac-dm1
8c	15	Vac-dm2			Vac-dm2		Vac-dm2					Vac-dm2
8a	16	Vac-dm3			Vac-dm3							Vac-dm3
9c	17					V-10%				V-10%	V-10%	V-10%
9a	18	TI//			TI//		TI//					TI//
10c	19						Déphasage					Déphasage
10a	20		Ures		Ures							Ures
11c	21			Um	Um							Um
11a	22			Uref	Uref			Uref				Uref
12c	23				Correct PID				Correct PID			Correct PID
12a	24						IsinØ					IsinØ
13c	25				Uregl			Uregl				Uregl
13a	26				Statisme D		Statisme D					Statisme D
14c	27				cosØ, KVAR		cosØ, KVAR					cosØ, KVAR
14a	28				IcosØ		IcosØ					IcosØ
15c	29				Sauto			Sauto				Sauto
15a	30								Smanu	Smanu	Smanu	Smanu
16c	31							cde lexc	cde lexc	cde lexc	cde lexc	cde lexc
16a	32	GND	GND	GND	GND	GND	GND	GND	GND	GND	GND	GND

AVR MODEL R630 / PMG

GENERAL DESCRIPTION

PIN	PIIN	Gen I/O	Mains I/O	Supply	Sensing	PID, limit	CosØ, KVAR	Pot dig U	Pot dig lex	Manu mode	Driver puiss	test output
17c	33	GND	GND	GND	GND	GND	GND	GND	GND	GND	GND	GND
17a	34	Mes lexc									Mes lexc	Mes lexc
18c	35	synchro									Perte synchro	Perte synchro
18a	36	I limit									I limit	I limit
19c	37	GND	GND	GND	GND	GND	GND	GND	GND	GND	GND	GND
19a	38	Fin rampe				Fin rampe					Fin rampe	Fin rampe
20c	39	U cosØ					U cosØ	U cosØ				U cosØ
20a	40		P.F/KVAR				P.F/KVAR	P.F/KVAR				P.F/KVAR
21c	41	U KVAR					U KVAR	U KVAR				U KVAR
21a	42	Pot tension				Pot tension						Pot tension
22c	43	U tension				U tension						U tension
22a	44	+lexc							+lexc			+lexc
23c	45	-lexc							-lexc			-lexc
23a	46	+Uauto						+Uauto				+Uauto
24c	47	-Uauto						-Uauto				-Uauto
24a	48	Cde reg cosØ				Cde reg cosØ						Cde reg cosØ
25c	49		Cde U=U			Cde U=U						Cde U=U
25a	50	cde auto/manu							Cde A/M	cde auto/manu	cde auto/manu	cde auto/manu
26c	51		Défaut T°C								Défaut T°C	Défaut T°C
26a	52											reserve
27c	53								Cde U	Cde U		Cde U
27a	54											reserve
28c	55											reserve
28a	56											reserve
29c	57											reserve
29a	58											reserve
30c	59								Max pot			Max pot lexc
30a	60							Max pot				Max pot U/P.F
31c	61											reserve
31a	62	Alarm									Alarm	Alarm
32c	63	-Vcc	-Vcc	-Vcc	-Vcc	-Vcc	-Vcc	-Vcc	-Vcc	-Vcc	-Vcc	-Vcc
32a	64	-Vcc	-Vcc	-Vcc	-Vcc	-Vcc	-Vcc	-Vcc	-Vcc	-Vcc	-Vcc	-Vcc

AVR MODEL R630 / PMG

GENERAL DESCRIPTION

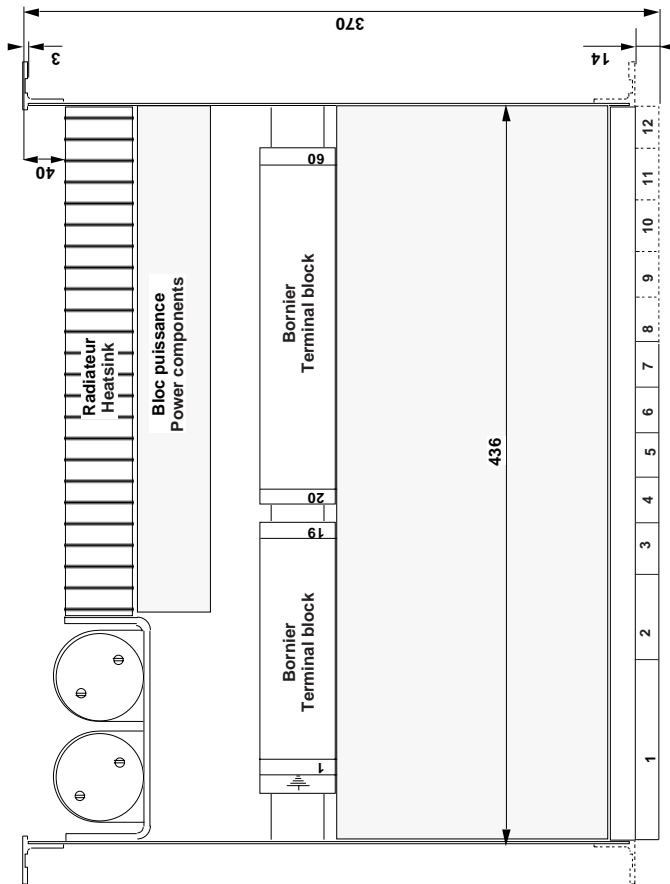
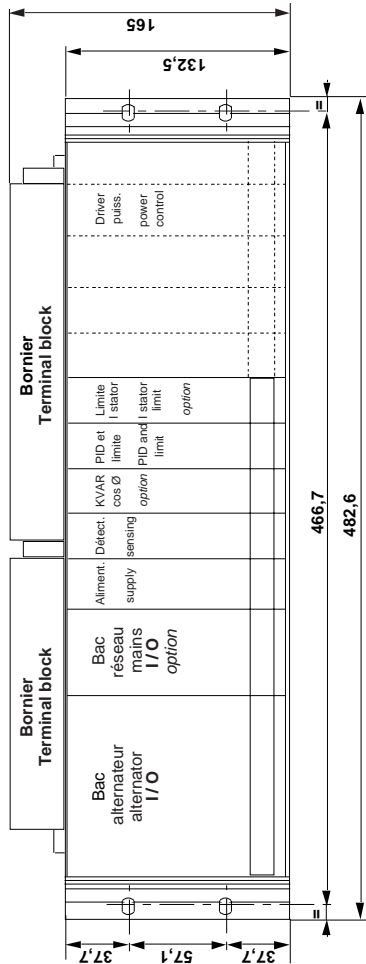
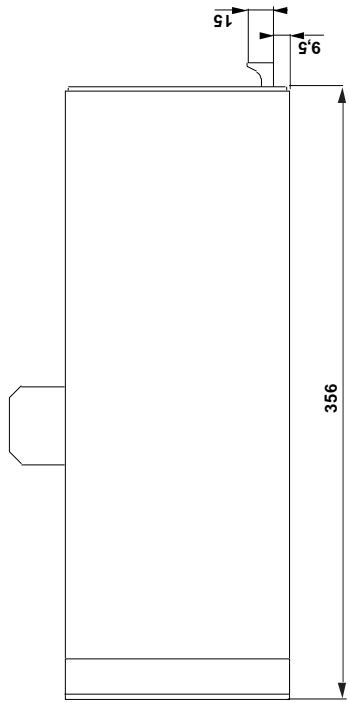

Des. : P. B	Verif. : L. D	Date : 30/12/92	Aeliers de Constructions Electriques
ENCOREMENT REGULATEUR de TENSION AUTO. VOLTAGE REGUL.GENERAL ARRANGEMENT			A C E O d'Orléans
SHUNT - - - Serie : R 600			45005 ORLEANS
N ° EN 182 2511			FRANCE

AVR Model R630

Generator I/O

1 - FUNCTIONAL

- This unit is mainly an interface between external signals and low power electronics.

- It is composed by :

- The adaptation three phases transformer between input voltage and measurement circuits.
- The burden resistor of parallel CT.
- The adaptation transformer between input voltage and low power electronic supplies.

- The interface input relays between command / control terminals and internal circuits.
- The interface between 64pts BUS and the analogic input / output terminals

2 - ADJUSTMENTS

- Setting of the auxiliary input voltage (terminals 16,17) : (110 or 220Vac) by jumpers.

3 - INPUT / OUTPUT

See following table

INPUT TERMINAL	Connector 32 PTS	Type I / O	Interface	Connector 26 PTS	Connector BUS 64 PTS
1	15c	measure	transfo 3Ø TP4	4	7a
1	15c	alim	transfo TP2		
2	13c	measure	transfo 3Ø TP4	2	8c
2	13c	alim	transfo TP1/2		
3	11c	measure	transfo 3Ø TP4	3	8a
3	11c	alim	transfo TP1		
9	16c	measure	resistance RTI	5	9a
10	10c	measure	GND	1	7c
16	1a	alim	transfo TP3		4c
17	1c	alim	transfo TP3		4a
20	10c	shield	GND	1	7c
21	7a	signal	resistance	13	11a
22	3c	signal	direct	14	21a
23	6c	signal	resistance	15	7c
24	3a	signal	direct	16	22c
25	4a	signal	direct	21	17a
26	10c	signal	GND	1	7c
27	5c	signal	resistance	6	1c
28	8a	signal	direct	17	20c
29	6a	signal	resistance	23	32a
30	12a	signal	resistance	6	1c
31	4c	signal	direct	19	21c
32	5a	signal	resistance	23	32a
33	14a	cmd input	relay	8	24a
34	2c	cmd input	relay		
37	7c	cmd output	relay	25	31a
38	9a	cmd output	relay	25	31a
39	10a	cmd output	relay	25	31a
40	2a	ext supply	relay		
41	2c	ext supply	relay		
42	14c	cmd input	relay	9	23a
43	13a	cmd input	relay	10	24c
44	2c	common	relay		
45	12c	cmd input	relay	11	22a
46	8c	cmd input	relay	12	23c
47	15a	cmd input	relay	7	25a
48	2c	cmd input	relay		
49	9c	cmd output	relay	12	23c
50	11a	cmd output	relay		

AVR Model R630

Generator I/O

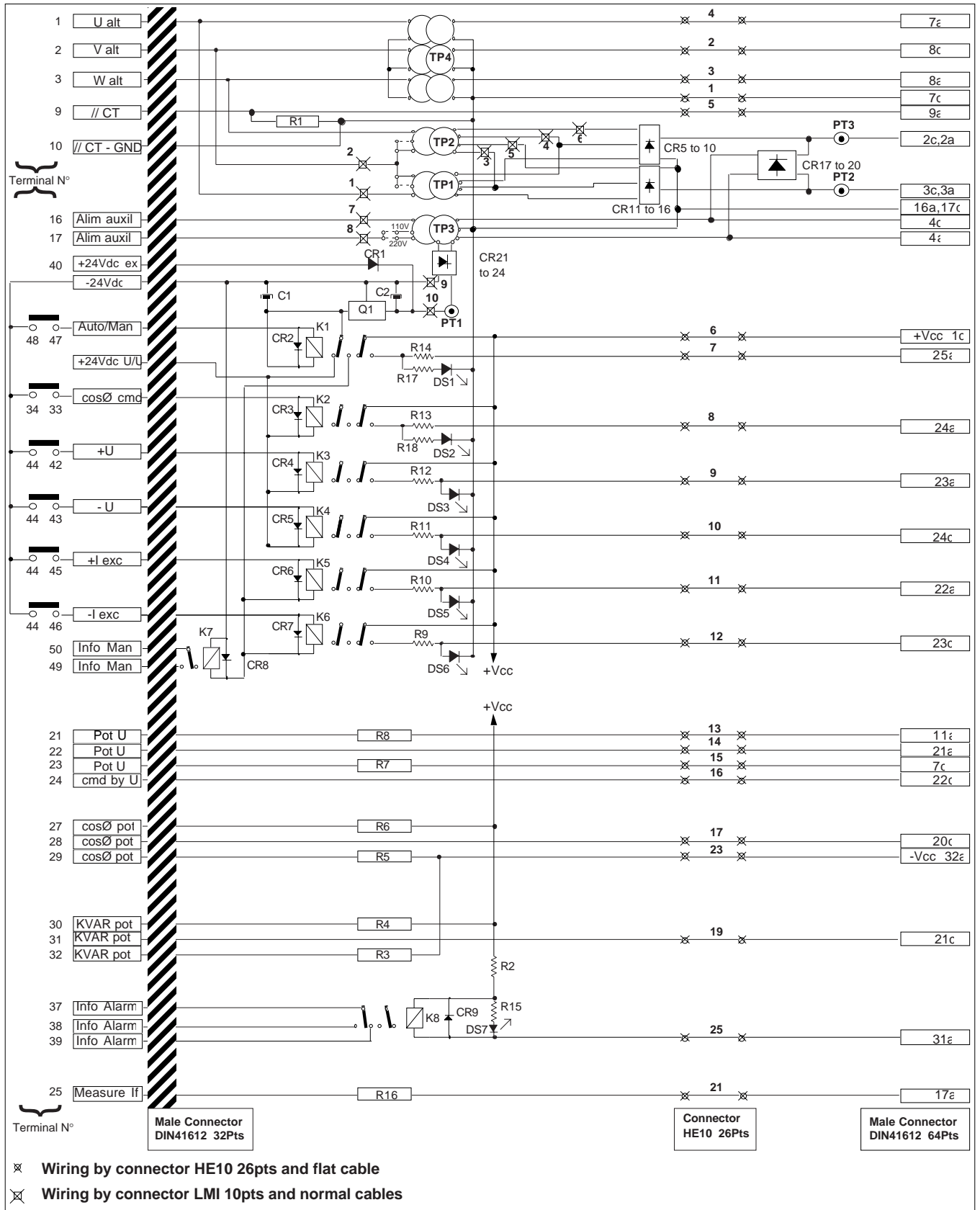

AVR Model R630

Generator I/O

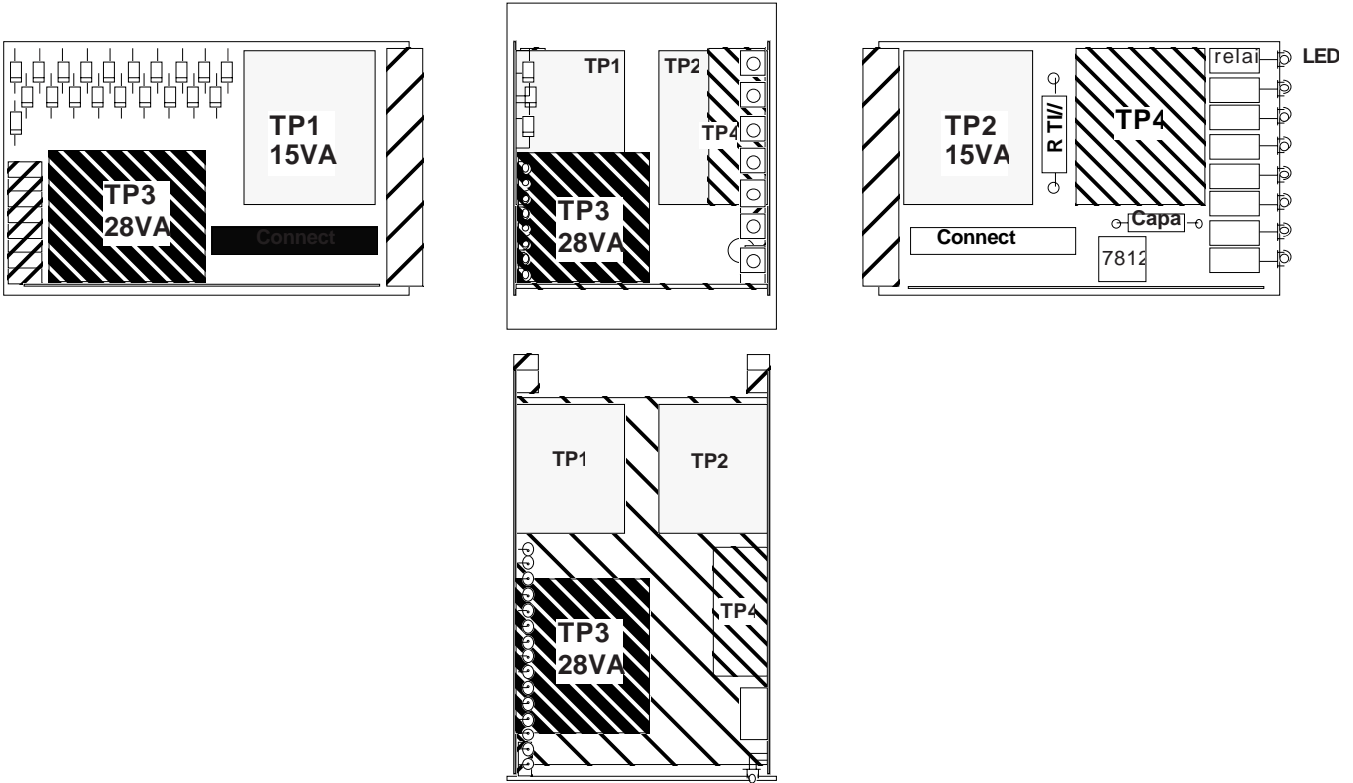

**ALTERNATEUR E / S
GENERATOR E / S**

	auto/manu <input type="checkbox"/>
	Cde cosØ <input type="checkbox"/>
	+U auto <input type="checkbox"/>
	-U auto <input type="checkbox"/>
	+I exc <input type="checkbox"/>
	-I exc <input type="checkbox"/>
	Alarm <input type="checkbox"/>

○	PT1
○	PT2
○	PT3

1 - FUNCTIONAL

- This card, from not regulated symmetrical voltage, generates +15Vdc and -15Vdc voltages with 0V common to both named +Vcc for +15V and Vdd for -15V in the following.
- The non regulated voltages are first filtered (C01, C02), pre-regulated to 20dc with ballast stages Q01 et Q02 and finally decreased to 15V by means of RG01 et RG02 regulators.
- Its permanent current capability is 0,5 Amp on both polarity.

2 - ADJUSTMENTS

None

3 - INPUTS / OUTPUTS

- 2a, 2c : Input +30Vdc not regulated
- 3a, 3c : Input -30Vdc not regulated
- 1a, 1c : Output +15Vdc regulated (Vcc)
- 32a, 32c : Output -15Vdc regulated (Vdd)
- 16a, 17c : Common electronic ground

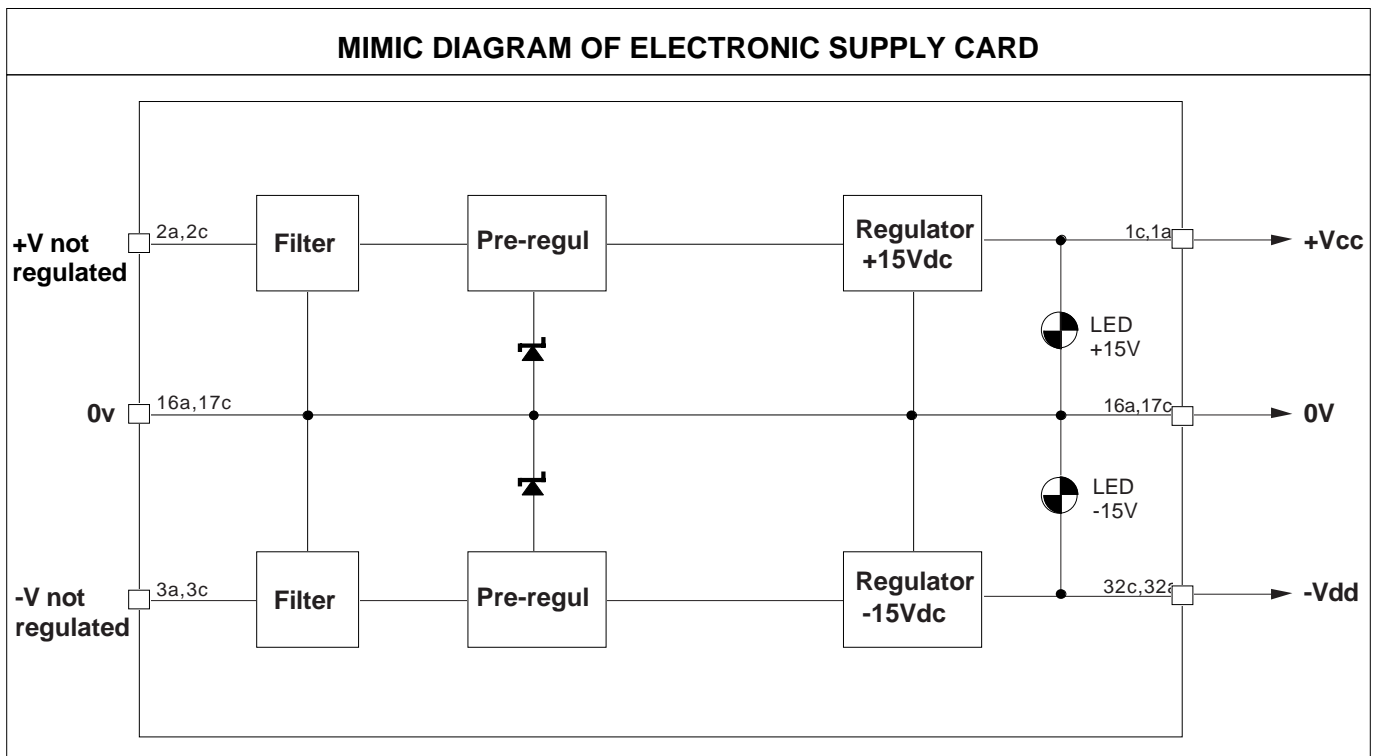

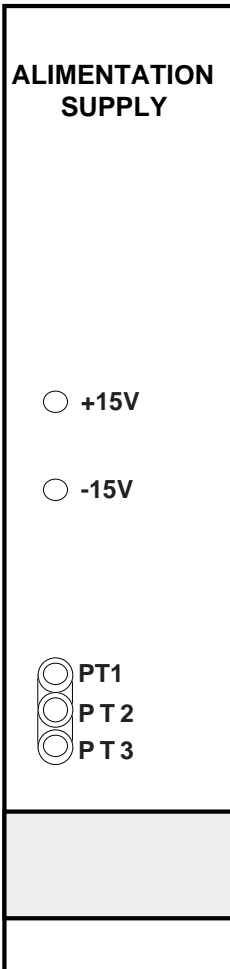
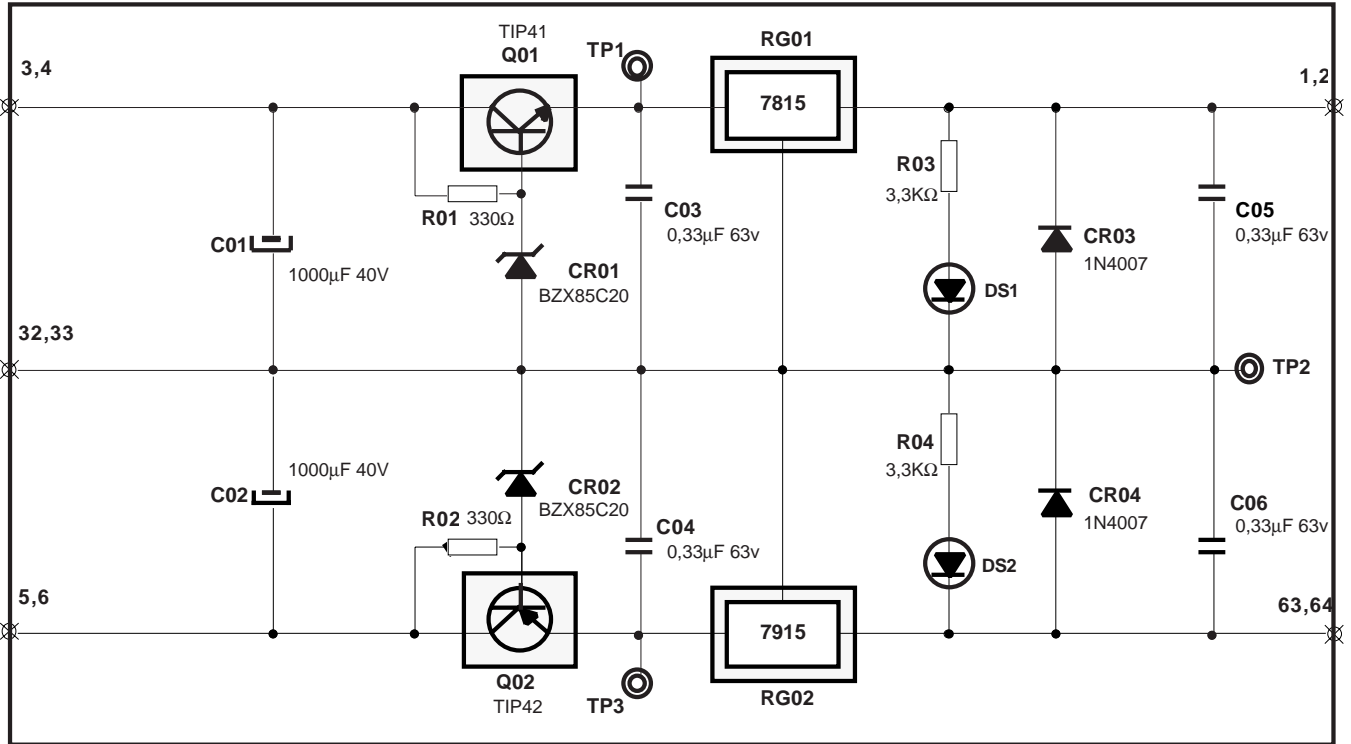

1 - FUNCTIONAL

- This card elaborates from the three phases voltage image of the generator given by the "ALTERNATOR I/O" :
- A rectified, calibrated, filtered voltage V_m proportional to the stator voltage of the generator. V_m could be affected by droop depending of adjustment.
- A voltage function of the generator frequency, a part of which gives the reference set point named V_{ref} .
- V_{ref} is a constant above the underfrequency threshold set point (signaled by LED) and decreases below this threshold following a function depending of the position of the strap CV1:
- In fixed V/Hz mode
- In adjustable kVolt / Hz (see curve below)

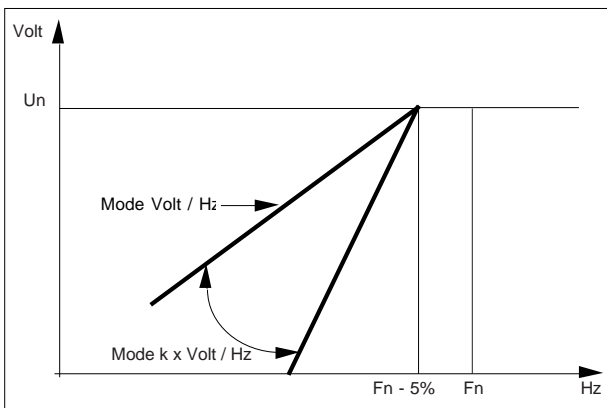

2 - ADJUSTMENTS

- P1 : Reactive droop adjust for parallel operation between equivalent machine.
- P2 : V_m adjust for nominal voltage. (9Vdc at U_n)
- P3 : Underfrequency threshold adjust (normally $F_n - 5\%$) signaled by LED.
- P4 : Underfrequency slope adjust (k) in kVolt / Hz mode ($1 \leq k \leq 2$)
- P5 : Voltage set point V_{ref} for the nominal voltage (10Vdc at U_n and F_n)

3 - INPUTS / OUTPUTS

- 7a, 8a, 8c : Voltage inputs image of the generator (3 x 21Vac between each and the GND)
- 9a : Current input image of the generator stator current (1Vac pour I_n)
- 1a,1c : +15Vdc regulated (V_{cc})
- 32a,32c : -15Vdc regulated (V_{dd})
- 16a,17c : Common ground (GND or 0V)
- 11c : Voltage output image of the generator (V_m) 10Vdc at U_n
- 11a : Voltage set point output (V_{ref}) 10Vdc at U_n and F_n

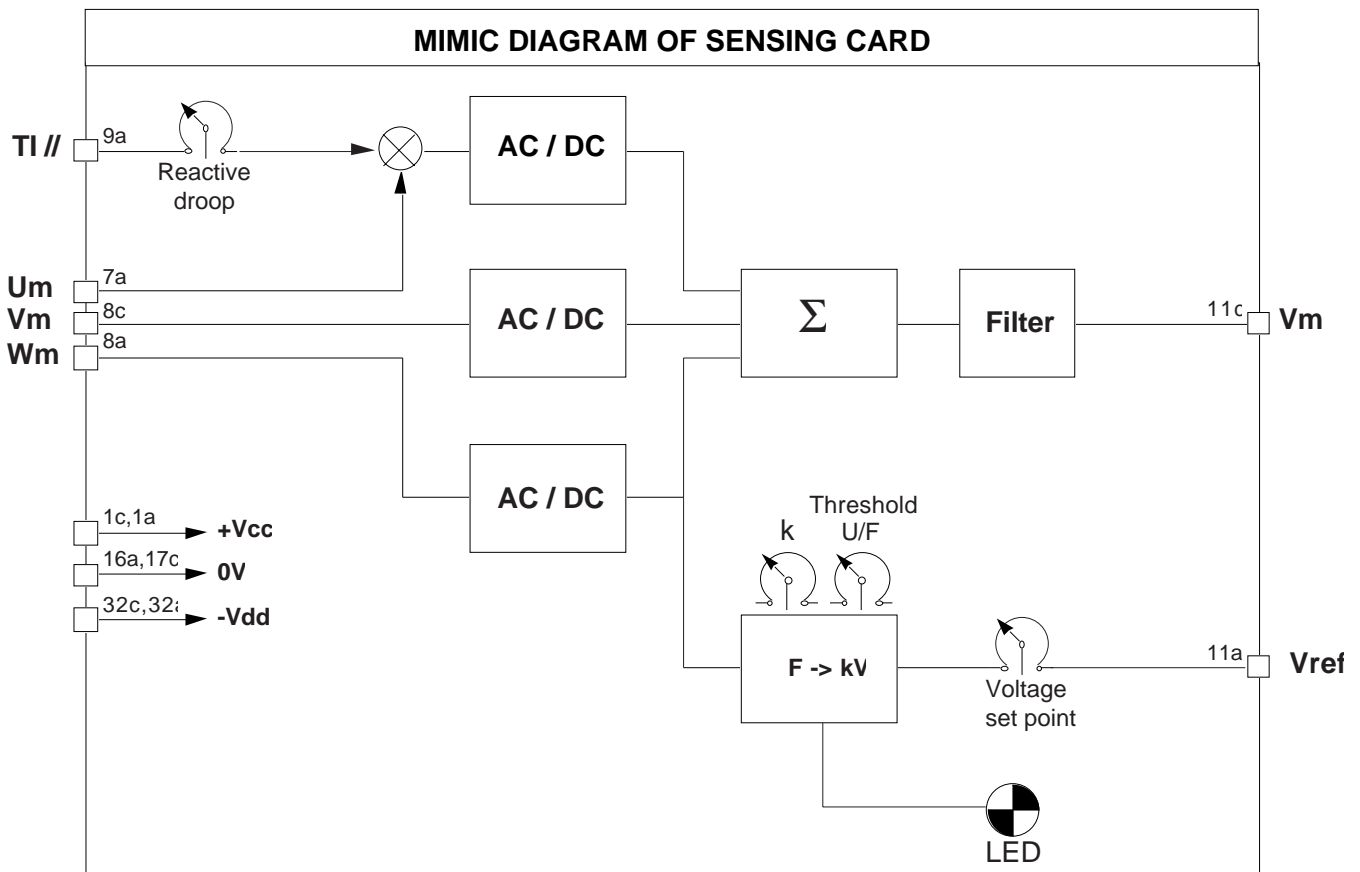

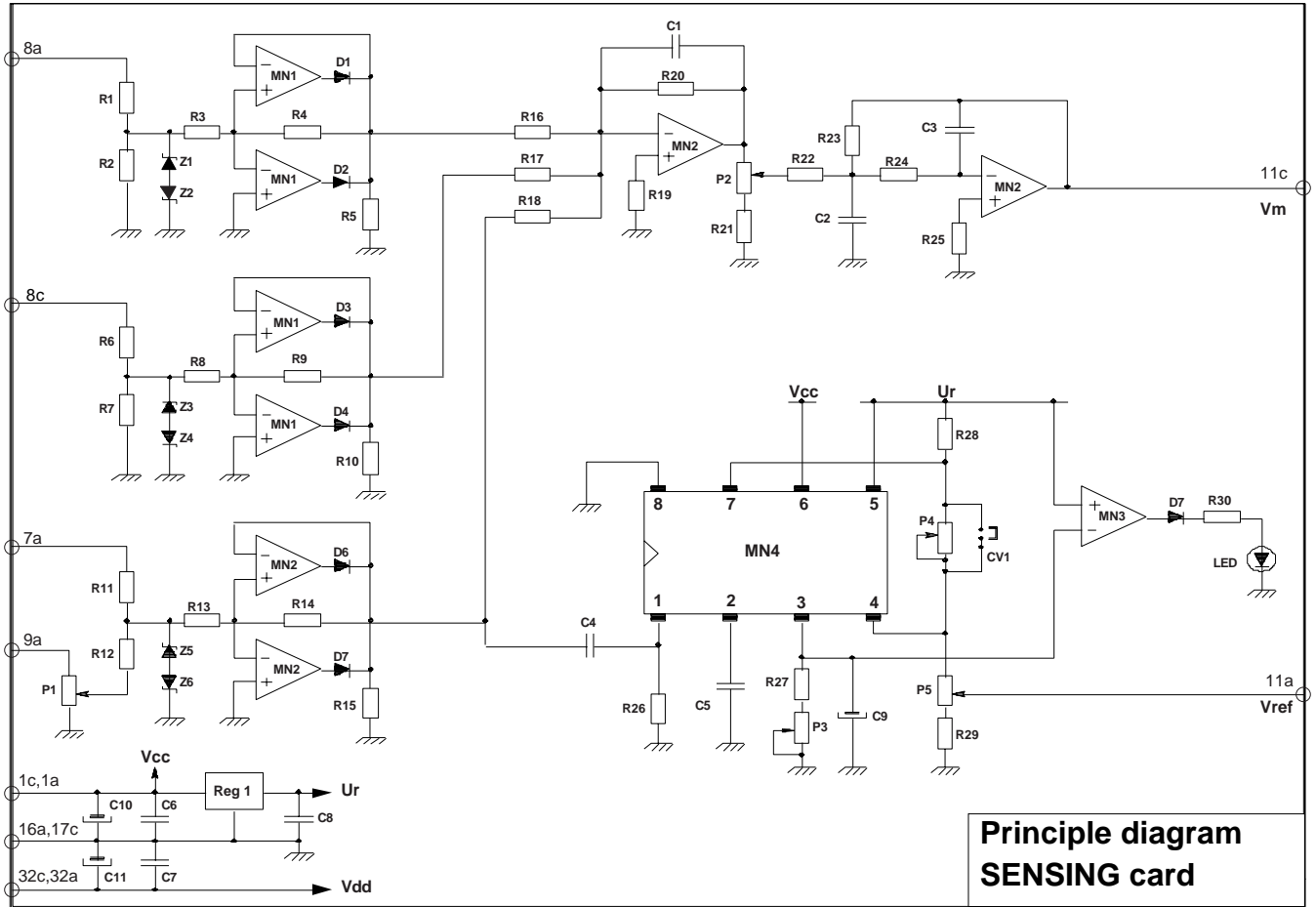

**FRONT VIEW
SENSING CARD**

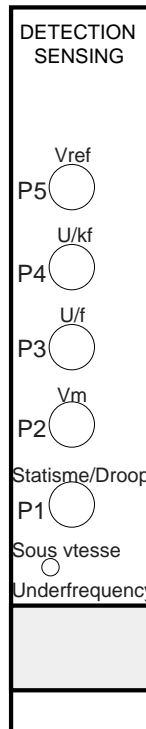

1 - FUNCTIONAL

- This card, from V_m (machine voltage image), V_{ref} (voltage set point) and complementary informations given in the following, elaborates the voltage command of the power driver card, which is the field current set point.

- Three operating modes are possible, depending of external informations :

- Solo operation or parallel operation between equivalent machines (1 Fonction)
(this is the normal mode)

- Parallel operation with the mains with power factor ($\cos\phi$) or KVAR regulation (2 Fonction)
(only if $\cos\phi$ / KVAR card is fitted)

- Operation in voltage equalization mode between machine and mains before coupling (3 Fonction)
(only if "MAINS I / O" CARD is fitted)

1F : Machine image V_{mis} compared with the sum of V_{ref} , P_{ext} , etc voltages depending of used options and the resultant voltage (error voltage) feeds the PID.

2F : When $\cos\phi$ cmd input is activated (+Vcc), the machine voltage V_m is compared to the voltage given from the $\cos\phi$ /KVAR card and the result (error voltage) feeds the PID.

3F : When U/U cmd input is activated (+Vcc), the machine voltage V_m is compared to the voltage given from the "MAINS I / O" card and the result (error voltage) feeds the PID.

A compensation external input, given for specific applications is added to the error voltage and the resultant voltage is the real PID input. Each branch (P, I, D) of the PID, independently adjustable from the others, set the time constants of the AVR in regard to the generator. The integrator branch can be short-circuited, for example when starting-up.

These three outputs are added, limited to 10Vdc and then give the field current set voltage of the "automatic channel" which is the driver card input.

The minimum value of this signal can be limited to avoid total loss of excitation of the generator. In case of parallel operation with the mains ($\cos\phi$ /KVAR card), this limitation is a function of the active power supply by the generator, this information is given by the $\cos\phi$ / KVAR card.

A separate stage detect if the generator voltage is below an adjustable value to unlock the normal field ceiling voltage from 110% of nominal to 160% (adjustable).

2 - ADJUSTMENTS

- P1 : Ceiling unlocked voltage threshold adjust (normally 90% U_n).
- P2 : Proportionnal branch gain adjust (large signal)
- P3 : Proportionnal branch gain adjust
- P4 : Integrative branch time constant adjust
- P5 : Derivative branch gain adjust
- P6 : Derivative branch time constant adjust
- P7 : Minimum field limitation adjust
- P8 : Minimum field limitation, active power correction adjust

3 - INPUTS / OUTPUTS

- 11a : Voltage reference set point input. V_{ref}
- 13c : Added signal to voltage reference set point input (option)
- 22c : Added signal to voltage reference set point input (external voltage option)
- 21a : Added signal to voltage reference set point input (external potentiometer option)
- 13a : Added signal to voltage reference set point input (differential droop option; with $\cos\phi$ /KVAR card)
- 19a : Integrator short-circuit command input
- 10a : Mains image voltage input (3F) (with "MAINS I / O" card only)
- 14c : $\cos\phi$ error voltage input (2F) (with $\cos\phi$ /KVAR card)
- 25c : Voltage equalization command input (3F) (with "MAINS I / O" card only)
- 24a : $\cos\phi$ regulation command input (2F) (with $\cos\phi$ /KVAR card)
- 1a,1c : +15Vdc regulated (V_{cc})
- 32a,32c : -15Vdc regulated (V_{dd})
- 16a,17c : Common electronic ground
- 14a : Minimum field limitation, active power correction input
- 15c : Field current voltage control output "AUTO" channel

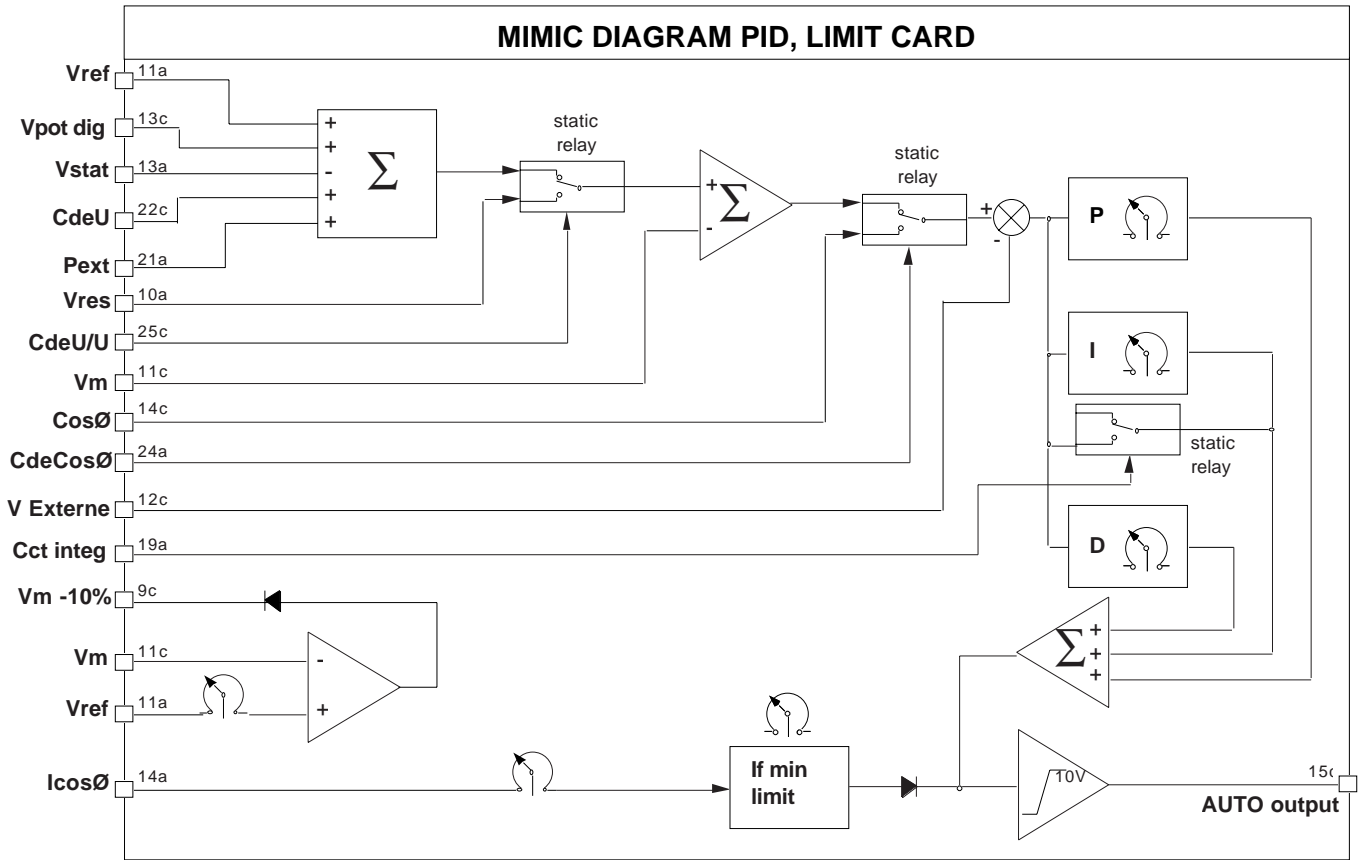

**FRONT VIEW
PID CARD**

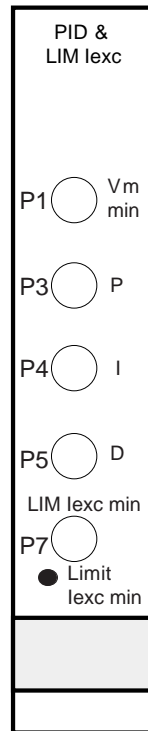

AVR Model R630

PID, LIMIT card

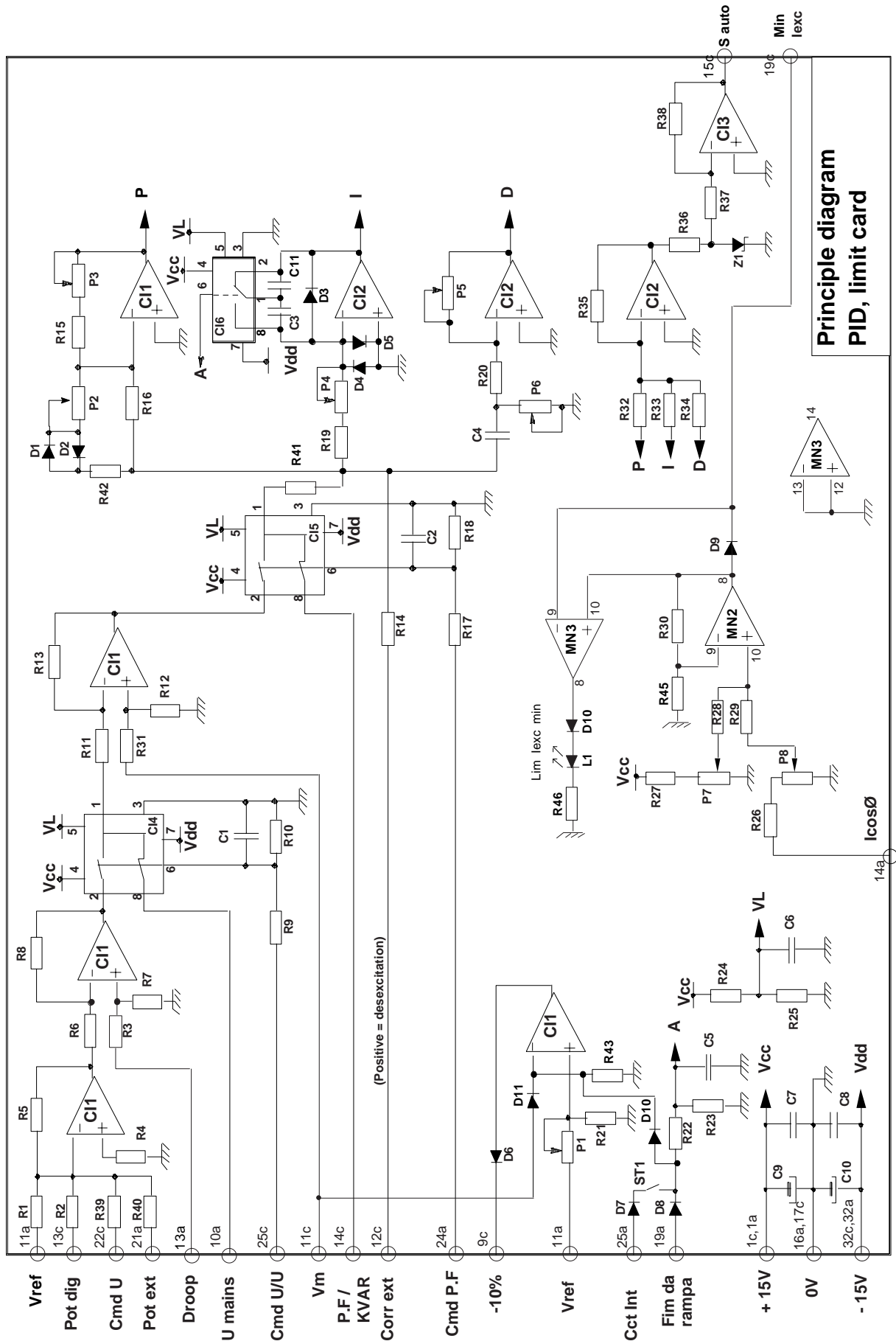

1 - FUNCTIONAL

This card controls from "AUTO" and "MANU" voltage reference and some additional informations detailed in the following, the exciter field current supply by the regulator and the booster (if used).

- Three operating mode are possible, depending of external informations :

- Normal mode with 110% ceiling of I_f nominal.
- Ceiling unlocked mode (160% minimum I_{field} nominal) depending of the command input from the PID card with limited delay and alarm output in case of sustained undervoltage.
- Maximum ceiling mode if the synchronisation voltage disappears (machine short-circuit) with limited (adjustable) field current.

- The "AUTO" or "MANU" reference voltage depending of the associated command input and also of the active limitations, is compared to the field current measurement and gives the error voltage which is after integration, compared to a sawtooth feed by the synchronisation voltage. The output of this stage is a variable duty cycle signal which controls the power transistors through isolating optocouplers.

- This card can be supplied in three manners :

- From the general supply of the rack in normal operation
- Through an isolated supply taken from the field voltage during start-up or generator short-circuit (Rack supply not present)
- Directly from the field voltage for power transistor command.

The permanent limitation (110% de I_{exc} nominal) can be modified by the following conditions:

- Field ceiling unlocking on machine undervoltage condition. It increases from 110% (normal operation) to a minimum of 160% of the nominal field current during an adjustable time delay and then go back to 110%. An alarm is activated if this undervoltage is sustained afterward.

- Field ceiling unlocking on synchronisation voltage cence. It increases to the maximum given by the setting of P7.

- Field ceiling limitation caused by power heatsink overheating. On thermocontact action the ceiling is reduced to a value given by the setting of P8.

A separate circuit monitors the instantaneous current of the power transistor and reduces immediatly the command signal if its value increases above a fixed value. (Exciter or wiring short-circuit protection).

2 - ADJUSTMENTS

- P1 : Integrator time constant adjust.
- P2 : Unlocked ceiling time delay adjust. (generally 5s)
- P3 : Alarm time delay adjust after ceiling unlock.
- P4 : Permanent ceiling value adjust (generally 1,1 I_f nominal)
- P5 : HALL sensor range adjust.
- P6 : Initial ramp-up adjust
- P7 : Maximum field current adjust (machine short-circuit)
- P8 : Maximum fieeld current in case of heatsink overheating.

3 - INPUTS / OUTPUTS

Flat cable (BUS 64points)

- 15c : I_f reference set point input "AUTO" channel
- 15a : I_f reference set point input "MANU" channel
- 25a : "AUTO / MANU" command input (0V = "AUTO")
- 9c : Unlocking ceiling command input
- 4a, 4c : Synchronisation voltage input
- 26c : Heatsink thermocontact input
- 1a,1c : +15Vdc regulated (Vcc)
- 32a,32c : -15Vdc regulated (Vdd)
- 16a,17c : Common ground (GND or 0V)
- 17a : Field current measure output
- 19a : End of ramp-up output signal
- 31a : Alarm output

Card connector (8 points)

- 1 : Field voltage
- 2 : Main transistor drain
- 3 : Main transistor gate
- 4 : Booster transistor gate
- 5 : Power ground
- 6 : +Vcc HALL sensor
- 7 : -Vcc HALL sensor
- 8 : HALL sensor measure output

MIMIC DIAGRAM DRIVER CARD

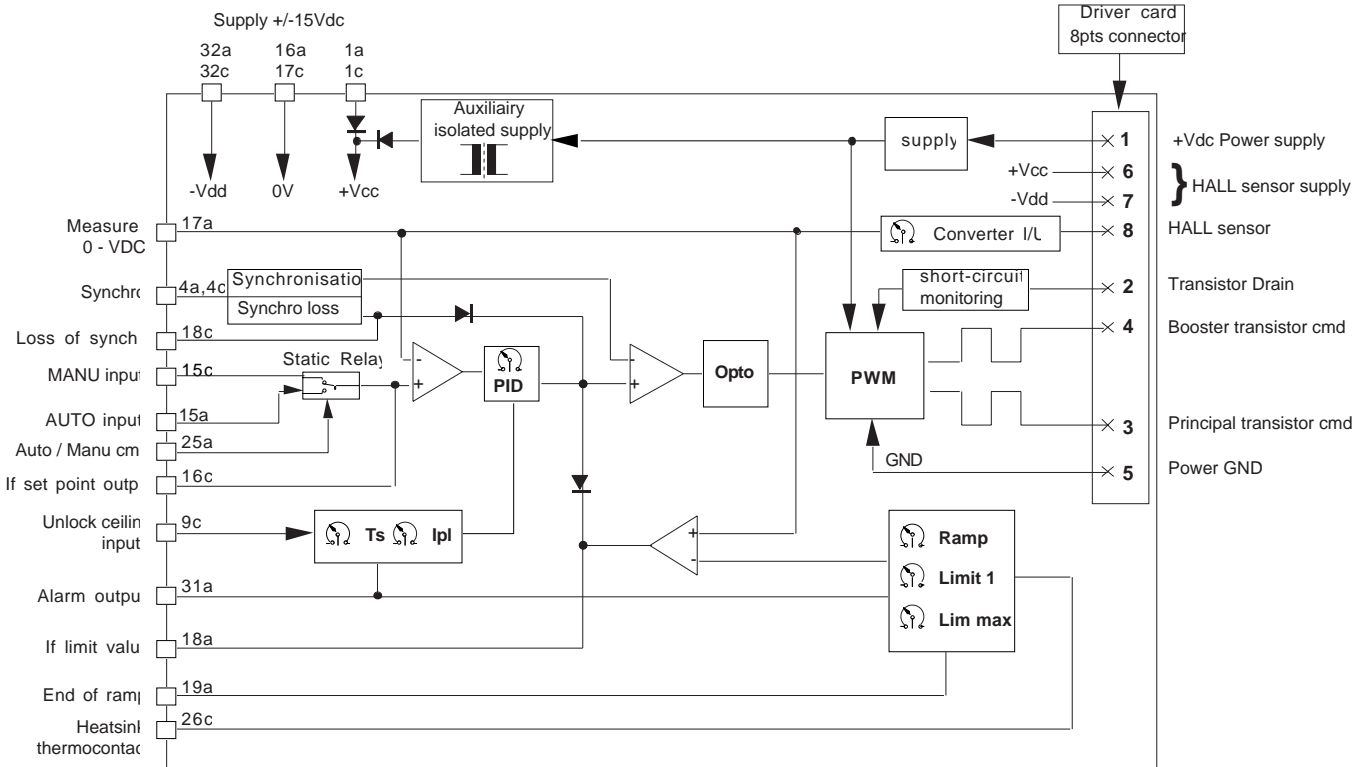

FRONT VIEW DRIVER CARD

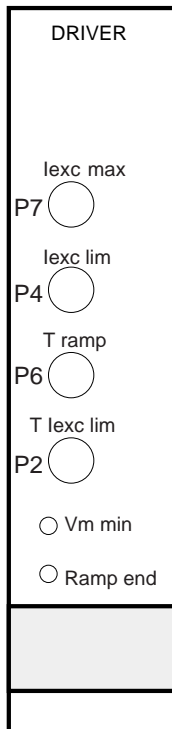

AVR Model R630

Driver card

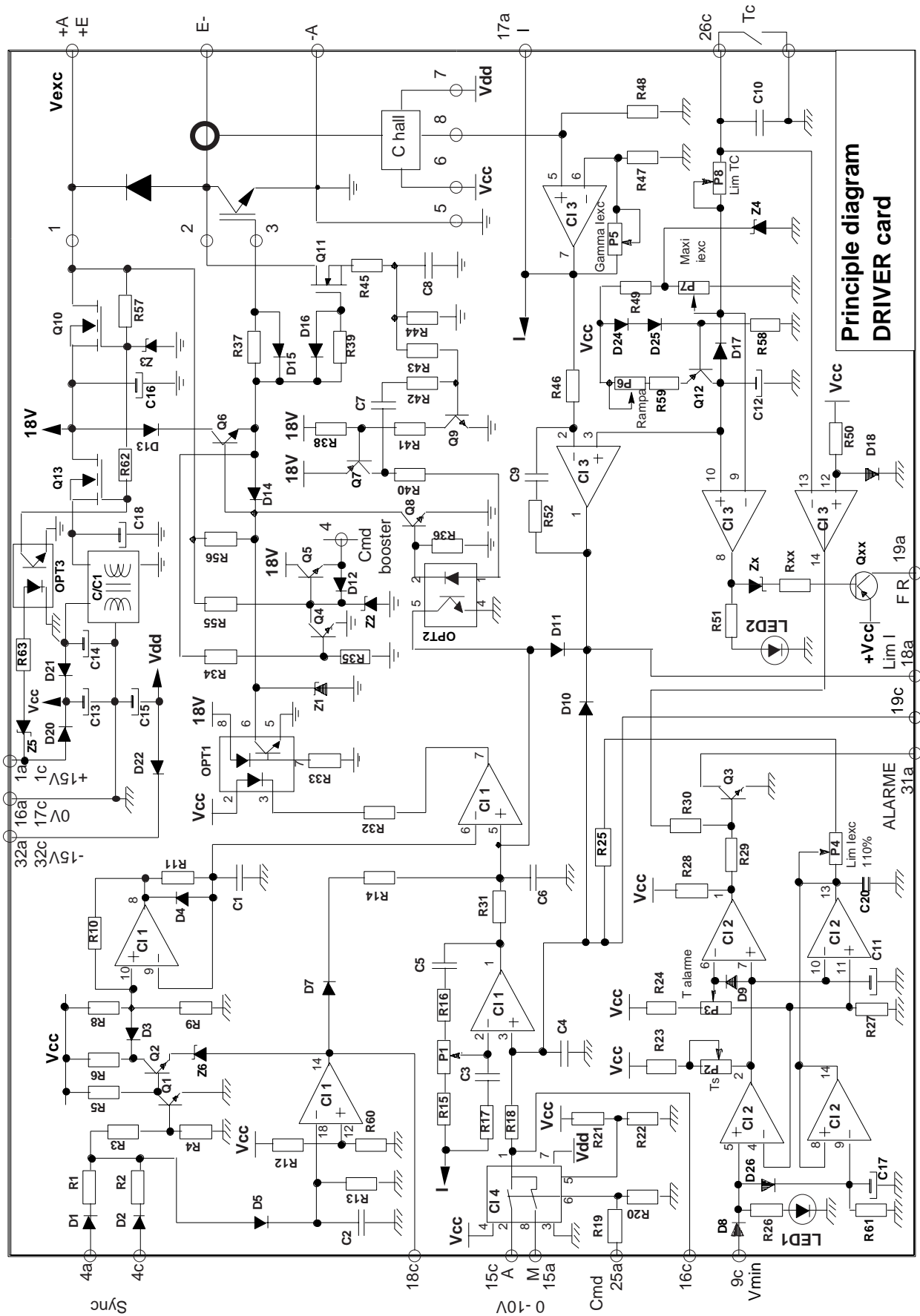

Principle diagram
DRIVER card

1 - FUNCTIONAL

This card elaborates from generator current and voltage informations, the following signals:

- An image of the reactive current of the generator named (KVAR) used for KVAR regulation.

- An image of the phase shift between the voltage and the current of the generator named (\emptyset) used for $\cos\emptyset$ (PF) regulation.

- An image of the active current of the generator named (KW) used for compensate the minimum I_{field} limit of the PID card.

- The principle of measurement is to sample and hold the instantaneous value of the current when the instantaneous voltage reaches zero on positive slope.

- First the current image of the stator current is filtered and used directly for KVAR measure. Then it is derivated and used for KW measure. And then it is amplified to obtain square waves and integrated to give a sawtooth used to \emptyset measure.

- The voltage image is phase-shifted to compensate the phase shift of the current input filter and after amplification is fed to a monostable which gives the pulse signal (about 100 μ s) used by all the sample and hold circuits.

- KVAR and \emptyset values are compared with an internal and external (if used) setting and the difference is send to the PID card as an error signal. An external contact control an analog switch to select what information between KVAR and \emptyset will be regulated.

- Three informations (\emptyset , $\Delta\emptyset$, Δ KVAR) can be used as an alternative droop for solo operation.

- \emptyset gives no droop at $\cos\emptyset=1$ and the voltage decreases at lagging PF.

- $\Delta\emptyset$ gives no droop at the $\cos\emptyset$ setting and the voltage decreases at more lagging PF and opposite for more ding PF.

- Δ KVAR gives no droop at the KVAR value setting and the voltage decreases with more KVAR and increases if less.

- The selection between these is made by mean of jum-

per (CAV) on the card (internal).

2 - ADJUSTMENTS

- P1 : KVAR internal setting.

- P2 : PF ($\cos\emptyset$) internal setting.

- P3 : Voltage phase shifter (internal)

- P4 : PF ($\cos\emptyset$) gain setting

- P5 : KVAR gain setting.

- P6 : Différential droop setting

- P7 : Pulse width setting (internal)

- Jumper CAV : Selection of droop type

No : Reactive droop adjusted by P1 (sensing card)

CAV1 : No droop for $\cos\emptyset=1$ and droop if lagging.

CAV2 : No droop for KVAR setting (P1), voltage decreases if more KVAR (lagging) and opposite if less.

CAV3 : No droop for PF setting (P2), voltage decreases if more lagging and opposite if less or leading.

Nota : If the droop is used from this card, potentiometer P1 of the sensing card must be set to zero.

3 - INPUTS / OUTPUTS

Flat cable (BUS 64points)

- 8c : Generator voltage image input

- 9a : Generator current image input

- 20a : Command input "cos \emptyset / KVAR"
(0V = "cos \emptyset ")

- 21c : External KVAR setting input

- 20c : External $\cos\emptyset$ setting input

- 1a,1c : +15Vdc supply (Vcc)

- 32a,32c : -15Vdc supply (Vdd)

- 16a,17c : Common electronic ground

- 14c : Error signal output to PID card

- 13a : Droop signal output to sensing card

- 14a : KW signal output to PID card

- 12a : KVAR signal output

- 10c : \emptyset signal output

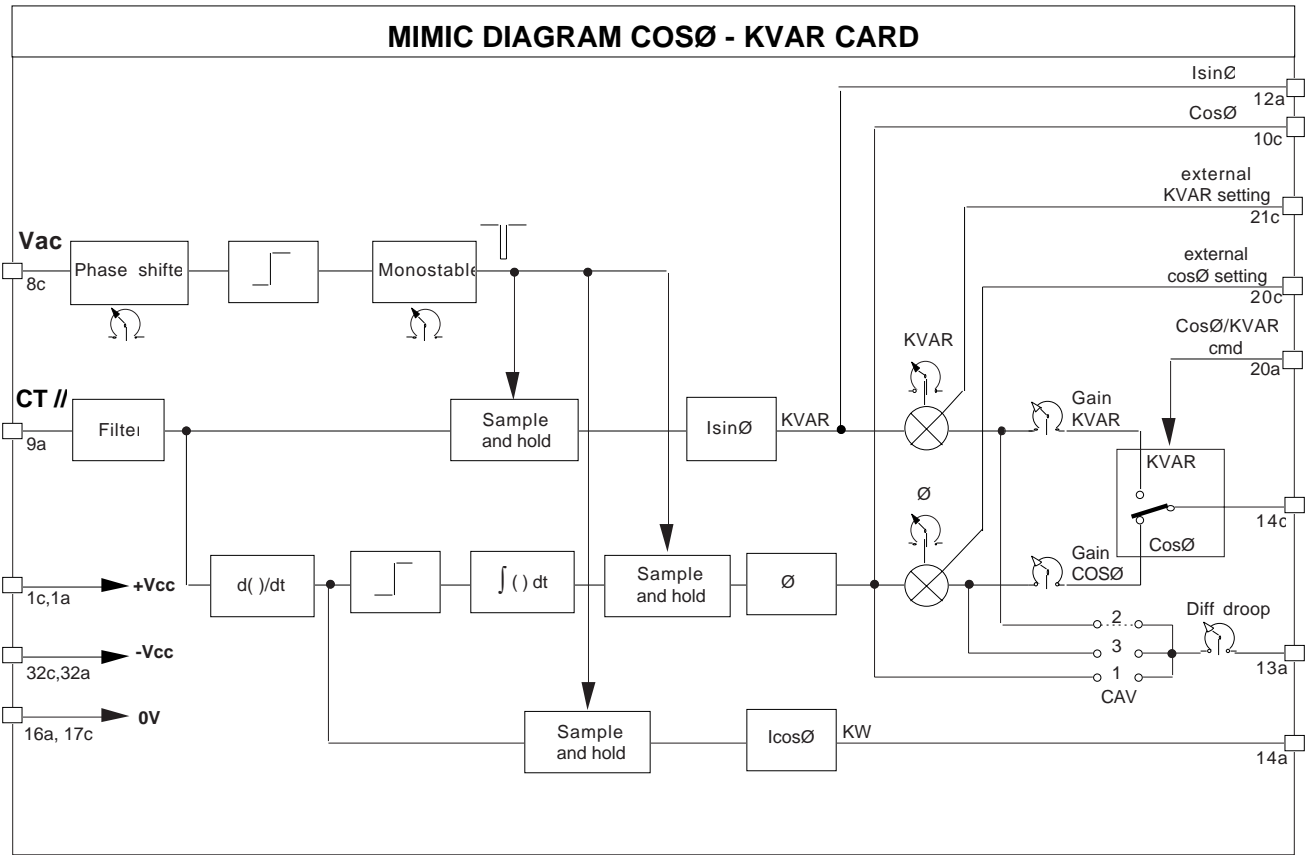

**FRONT VIEW
COSØ - KVAR card**

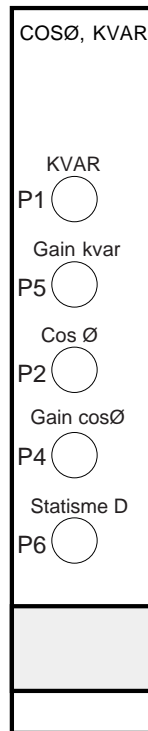

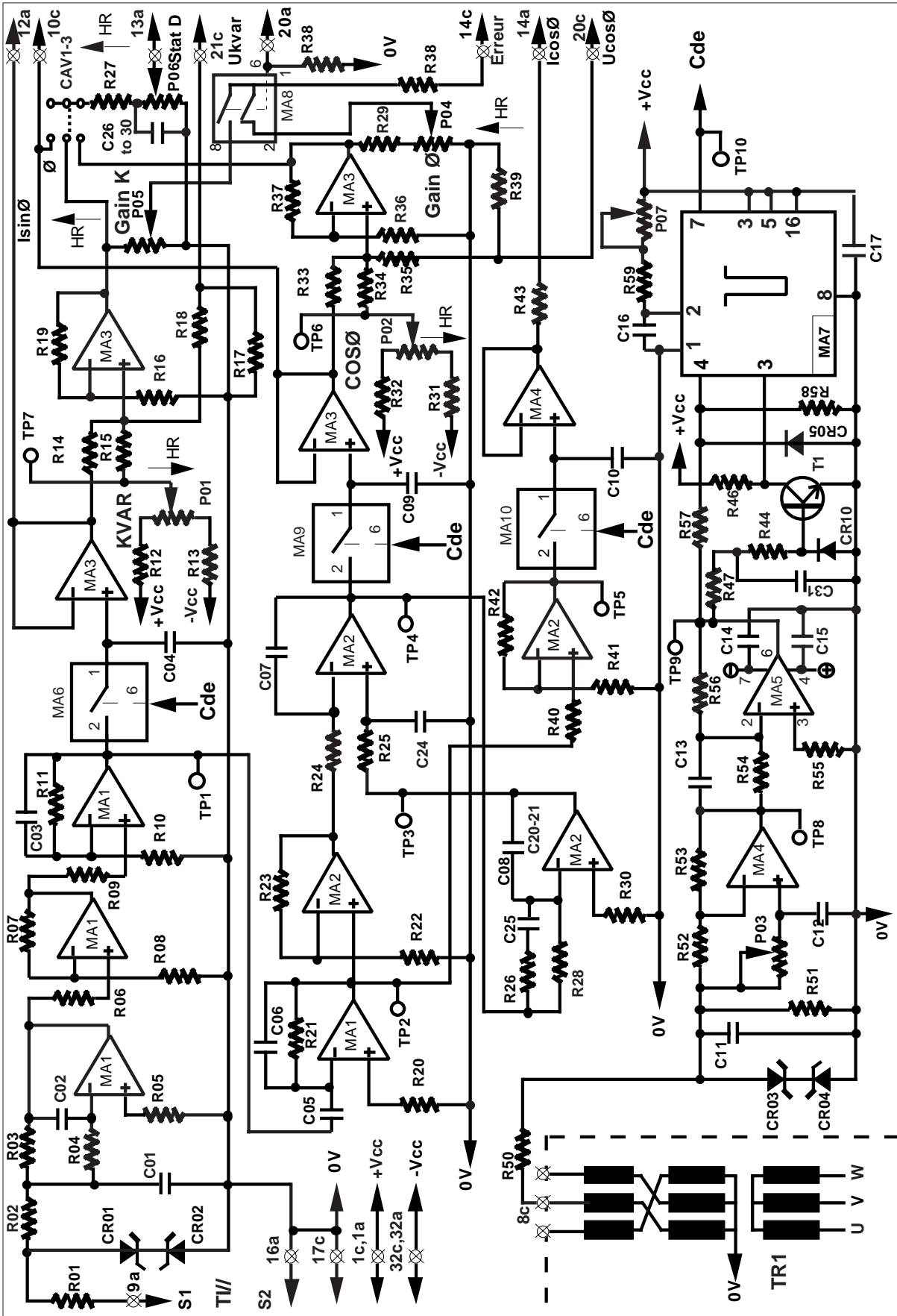

principle diagram
COSØ - KVAR card

1 - FONCTIONNAL

- This unit is mainly an interface between external signals and low power electronics.

- It is composed by :

- The adaptation three phases transformer between input voltage and measurement circuits.
- The AC/DC converter to give an image voltage of the mains voltage.
- The interface input relays between command / control terminals and internal circuits.
- The interface between 64pts BUS and the analogic

input / output terminals.

2 - ADJUSTMENTS

- P01 : Ur setting for mains nominal voltage. (10Vdc for nominal value)

3 - INPUT / OUTPUT

See following table.

INPUT TERMINAL	Connector 32 PTS	Type I / O	Interface	Connector 26 PTS	Connector BUS 64 PTS
12	15c	sensing	3Ø transformer TP4	13	5a
13	13c	sensing	3Ø transformer TP4	17	6c
14	11c	sensing	3Ø transformer TP4	21	6a
51	1a	signal	direct	3	15a
52	3a	signal	direct	5	27c
54	2a	spare		7	27a
55	4a	spare		2	28c
56	5a	spare		4	28a
57	6a	spare		6	29c
58	7a	spare		8	29a
59	8a	spare		10	30c
60	9a	spare		12	30a
36	4c	cmd input	relay	1	25c
	2c	cmd input	relay	9	1c
53	3c	cmd input	relay	14	20a
	2c	cmd input	relay	9	1c
	10c	GND	direct	25	16a, 17c
	9c	thermocontact	direct	26	26c

AVR Model R630

Optional mains I/O

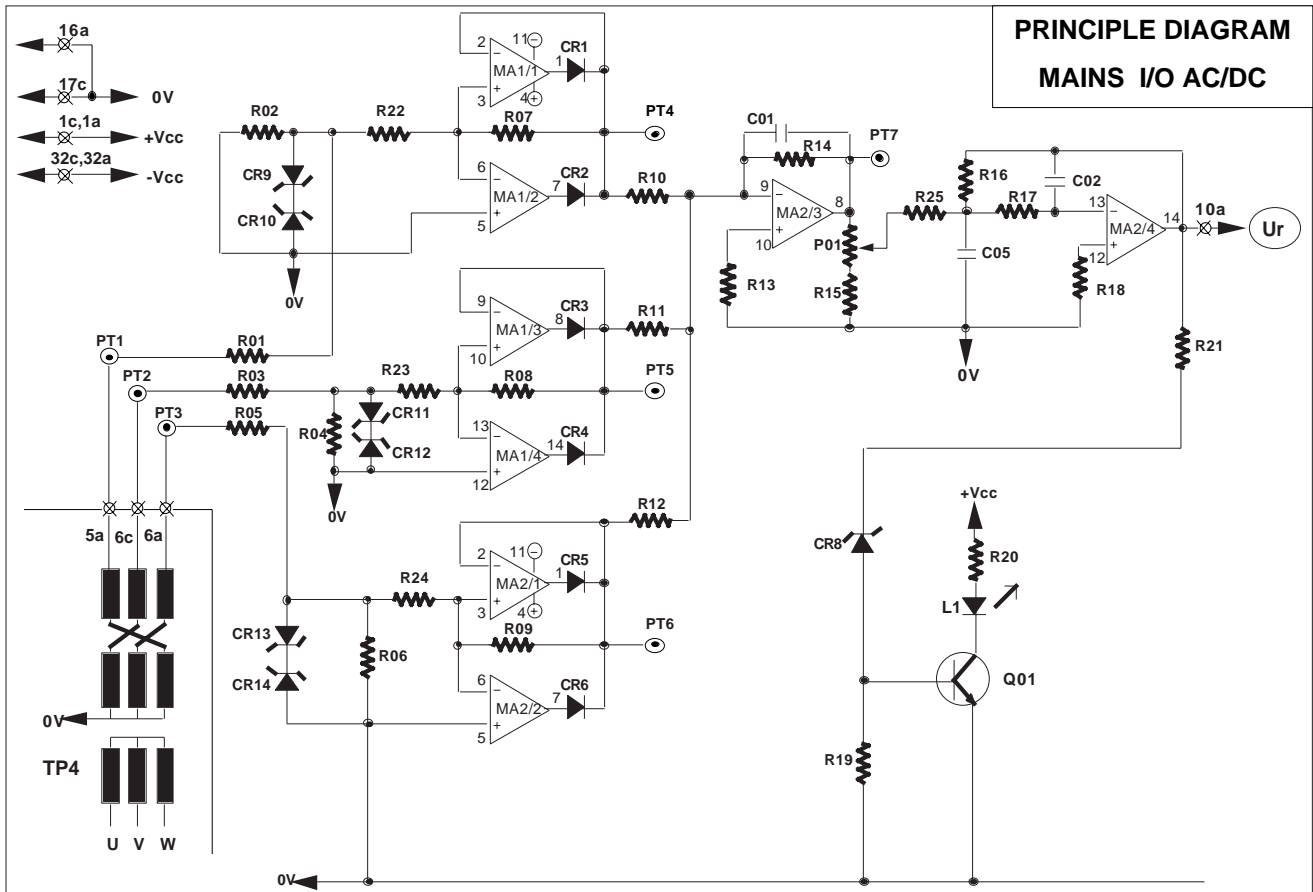
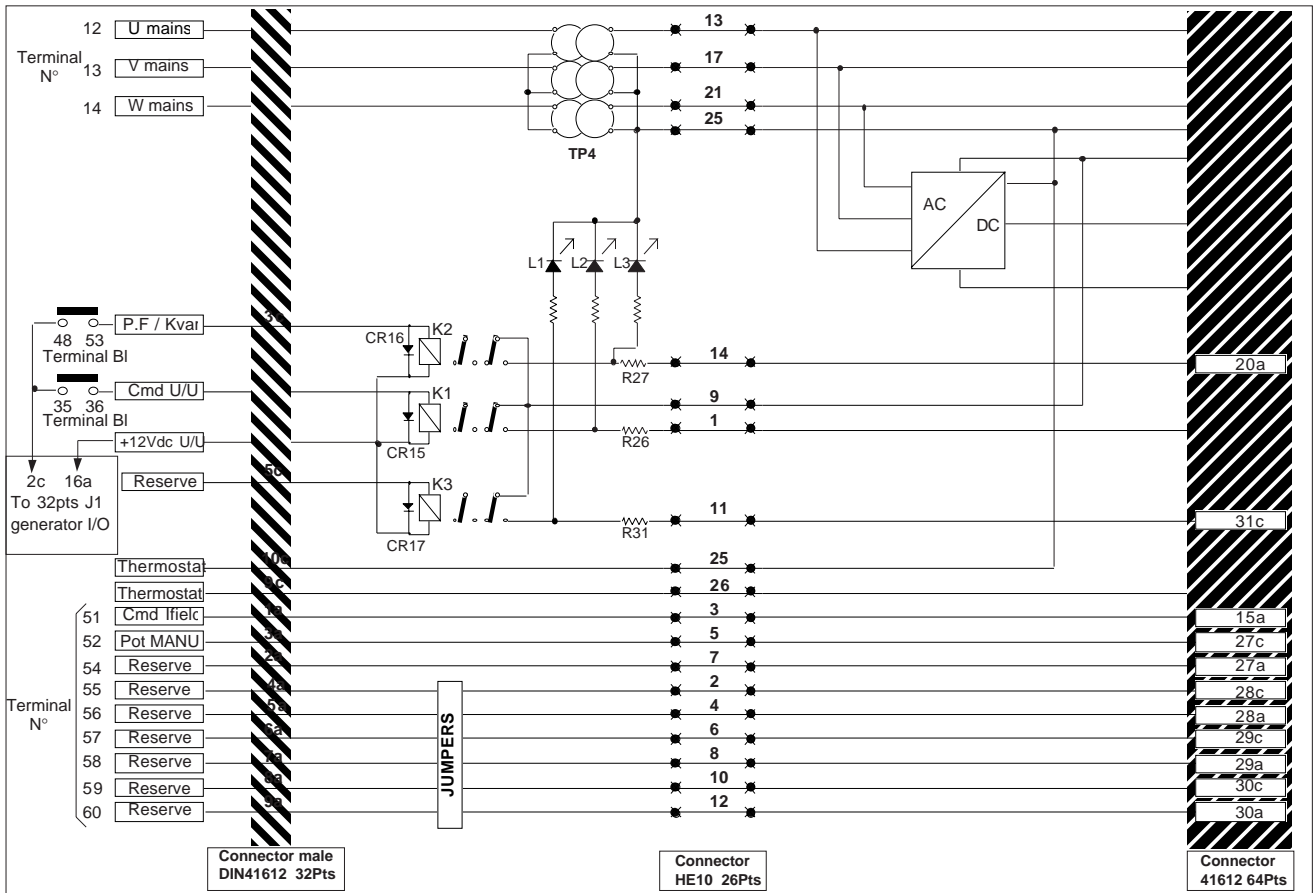

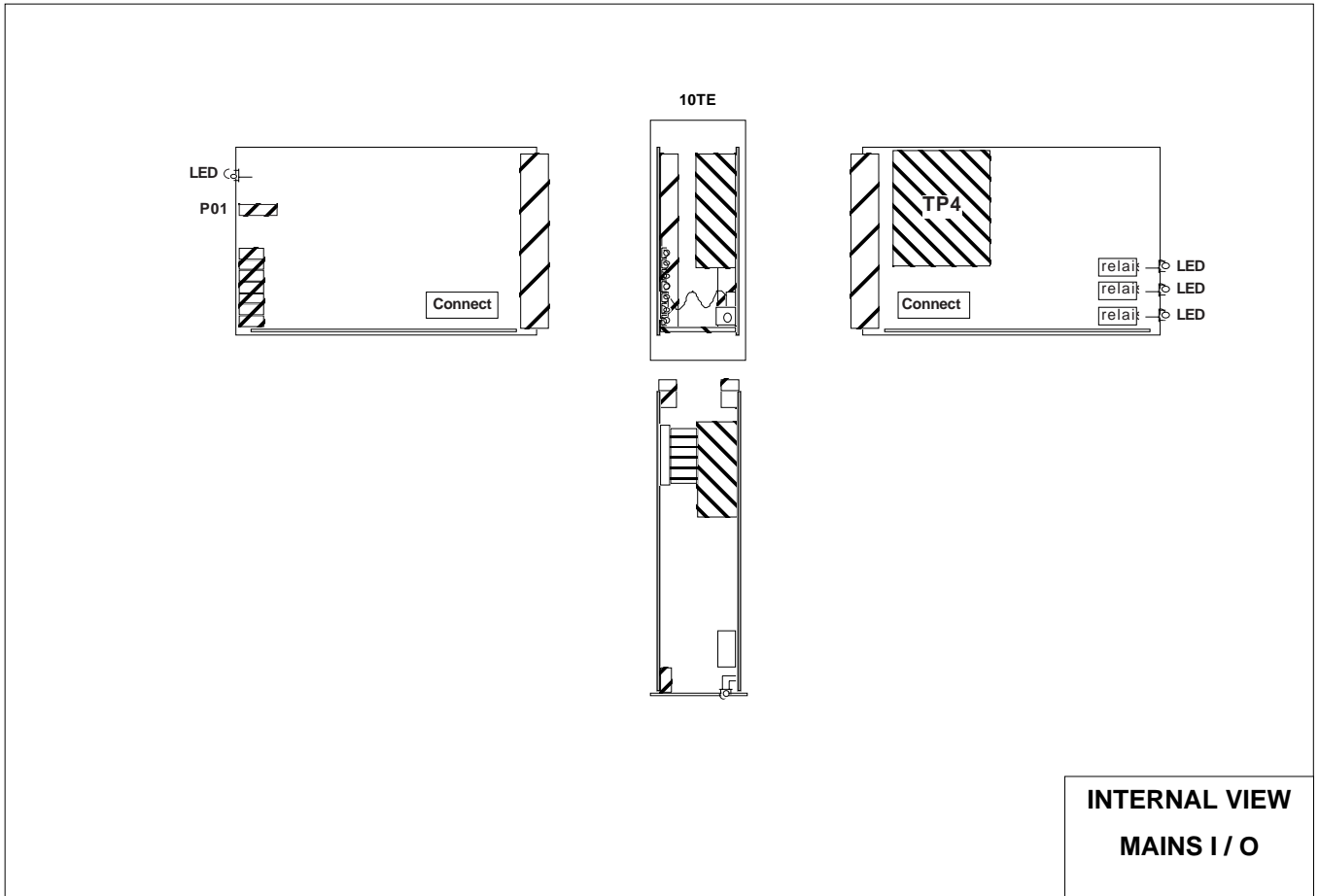

**FRONT VIEW
MAINS I / O**

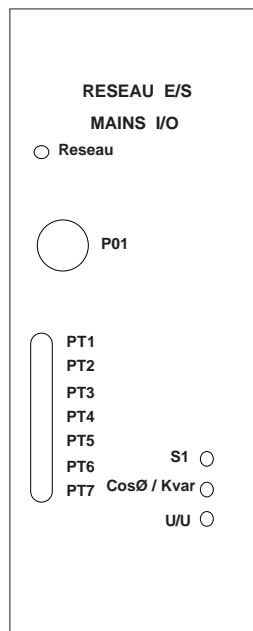

AVR Model R610 / R630

Digital pot U / P.F Optional card

1 - FUNCTIONAL

This card replace two conventional motorized potentiometers :

- One for the remote voltage setting.
- One for power factor or reactive current setting.

- Switch between the two modes is made by the external P.F regulation order (terminals 33, 34) and switch between P.F and KVAR setting is made by the external order (terminals 48,53)

- Each last position is memorized when the control is switched or when the machine is stopped.

- Jumps (SW1 and SW2) allow the choice between unipolar or bipolar voltage output and the range is adjusted by means of potentiometers P02 and P03.

- Jumps SW3 and SW4 must be open for normal operation and are only used for special applications.

- Speed of all adjustments is controled by potentiometer P01.

- Two LED's (L1,L2) indicate the command orders + or - and four other LED's (L3,L4 and L5,L6) indicates the maximum and minimum position of voltage and P.F settings

NOTE : When this card fitted, the internal voltage setting (P05 on sensing card) must be used to give the center position of the range (if bipolar range) or the minimum setting in case of unipolar range (idem for P.F and Kvar internal setting on P.F card). An external setting potentiometer must not be used, the settings are made only by mean of push-buttons on terminals 42, 43, 44.

2 - ADJUSTMENTS

- P1 : Clock speed (total range time)
- P2 : Voltage range value
- P3 : P.F or KVAR range value
- SW1: Voltage range polarity (0/+ or +/-)
- SW2: P.F or KVAR range polarity (0/+ or +/-)

3 - INPUTS / OUTPUTS

Flat cable (BUS 64 points)

- 24c : Cmd lower
- 23a : Cmd upper
- 16c : If reference set point input
- 15c : If reference set point input "AUTO" channel
- 24a : External P.F regulation order
- 20a : External P.F or KVAR regulation order
- 13c : Voltage setting output to PID card
- 20c,21c : P.F or KVAR setting output to P.F card
- 30a : Maximum position of settings
- 1a,1c : +15Vdc regulated (Vcc)
- 32a,32c : -15Vdc regulated (Vdd)
- 16a,17c : Common ground (GND or 0V)

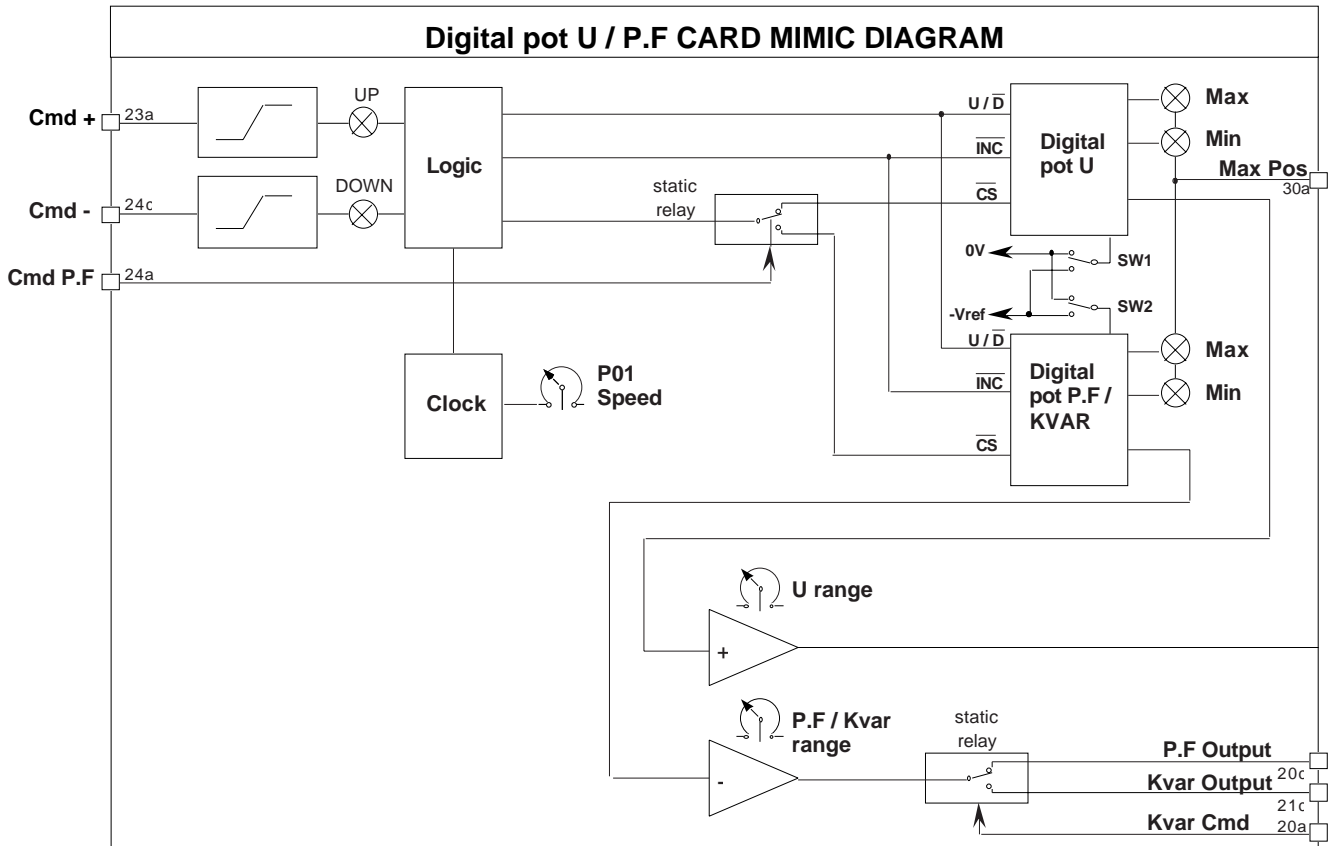

**FRONT VIEW
Digital pot U / P.F**

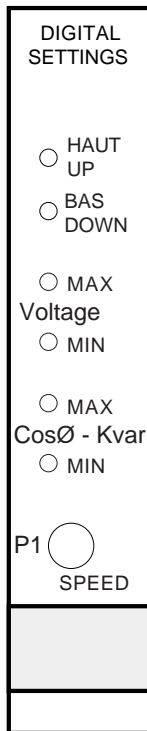

AVR Model R610 / R630

Digital pot U / P.F Optional card

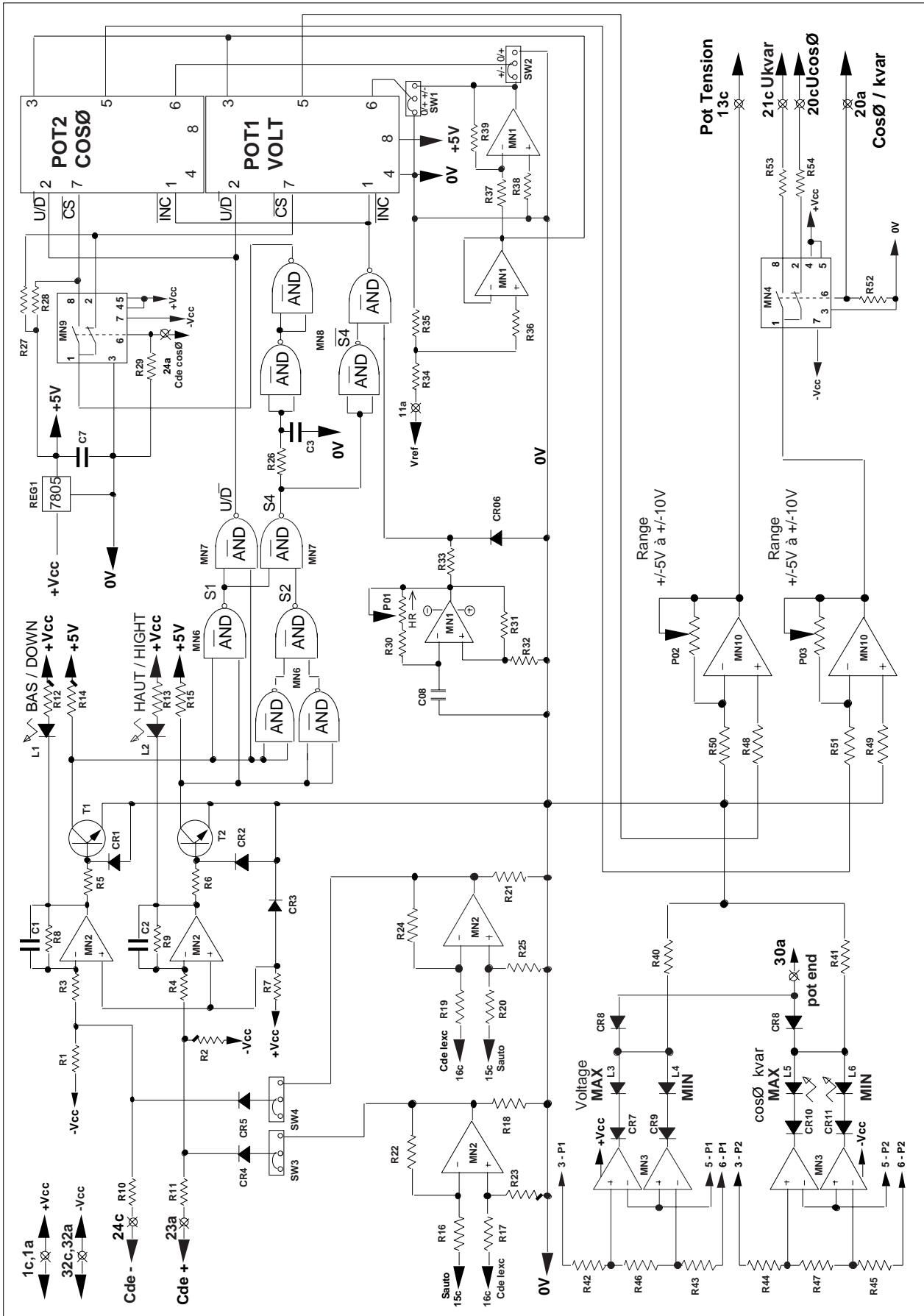

Principle diagram
Digital pot U / P.F / KVAR

1 - FUNCTIONAL

This card elaborates from internal setting (P02) and external setting informations, the I_{field} command signal given to "MANU" channel of the driver card.

- The I_{field} output signal is limited or reduced if the generator voltage exceeds the limitation value sets by the potentiometer P01 (trip of the main breaker on load for example).

- This case of operation is indicated by the LED "LIMIT" and the I_{field} setting must be decreased to a point under control.

- On MANU operation, the difference between MANU output and AUTO channel output gives a compensation signal which is used to compensate the PID to have always the MANU and AUTO channels outputs identical. With this circuit a smooth switching between MANU to AUTO is possible and operation will go back to the AUTO channel own settings.

- The ceiling can be unlocked on this operation, that is why it can be necessary to wait some seconds after the switching to return on MANU operation.

- On AUTO operation, these two channels are also monitored and the difference is indicated by three LEDs.

- HIGH says that MANU channel is higher than AUTO
- LOW says that MANU channel is lower than AUTO
- OK says that MANU and AUTO channels are identical and smooth AUTO ---> MANU switching is possible.

NOTE : If a I_{field} digital potentiometer is used, the internal setting (P02) must be set to 0 or under the no load field value and an external setting potentiometer must not be used. In that case the setting is made only by mean of push-buttons on terminals 44, 45, 46.

2 - ADJUSTMENTS

- P1 : Voltage limitation setting
- P2 : Internal I_{field} value setting
- P3 : PID compensation gain setting
- P4 : Internal compensation setting

3 - INPUTS / OUTPUTS

Flat cable (BUS 64points)

- 4c : 24Vac input image of the generator from "generator I/O" card
- 25a : "AUTO / MANU" command input (0V = "AUTO")
- 16c : I_f reference set point input
- 15c : I_f reference set point input "AUTO" channel
- 27c : External I_{field} setting input
- 1a,1c : +15Vdc regulated (Vcc)
- 32a,32c : -15Vdc regulated (Vdd)
- 16a,17c : Common ground (GND or 0V)
- 15a : I_f set point output "MANU" channel
- 12c : PID compensation output
- 9c : Ceiling locked output

AVR Model R630

Manual mode 1 Optional card

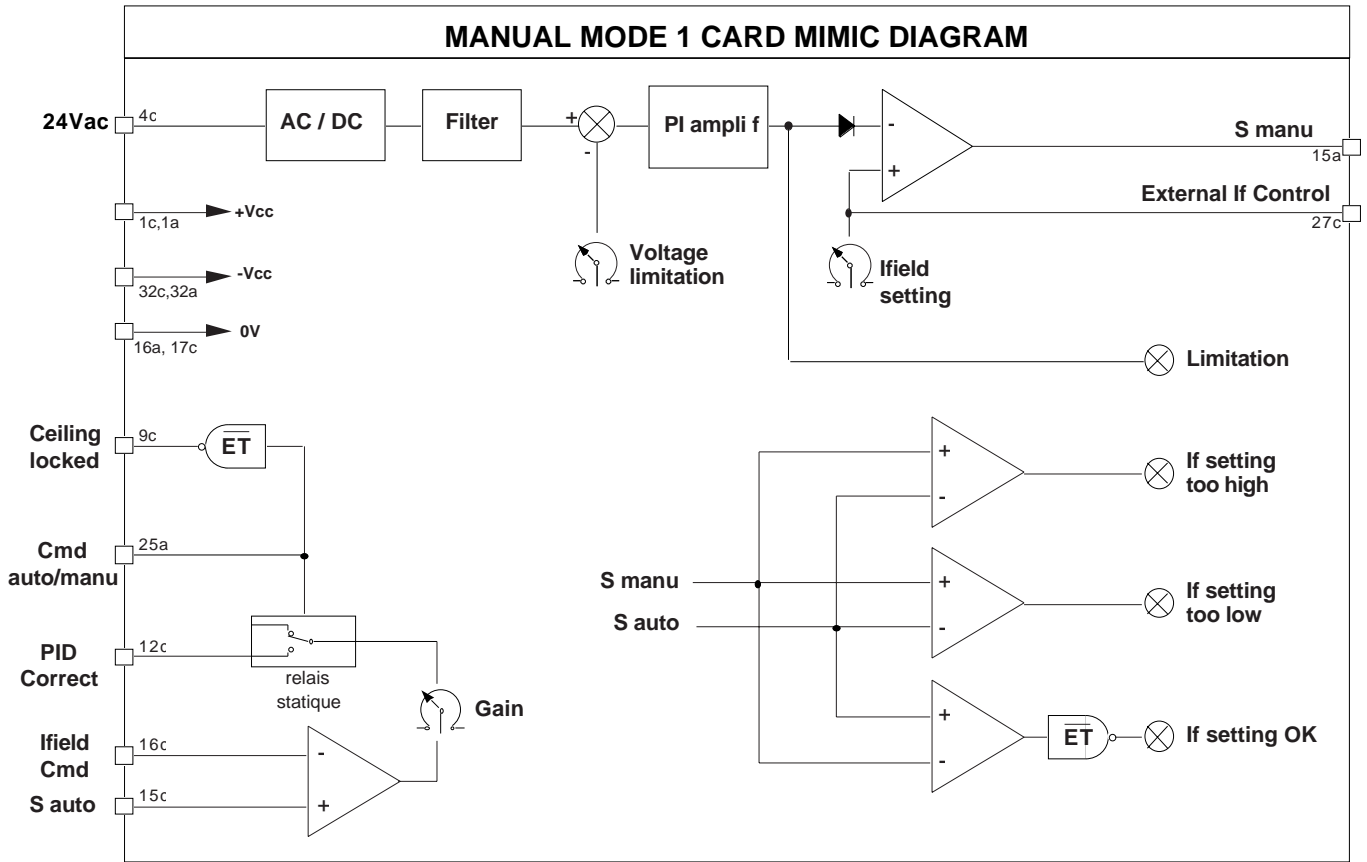

**FRONT VIEW
Manual mode**

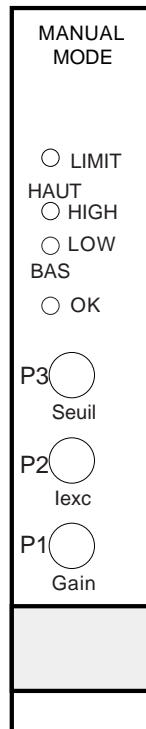

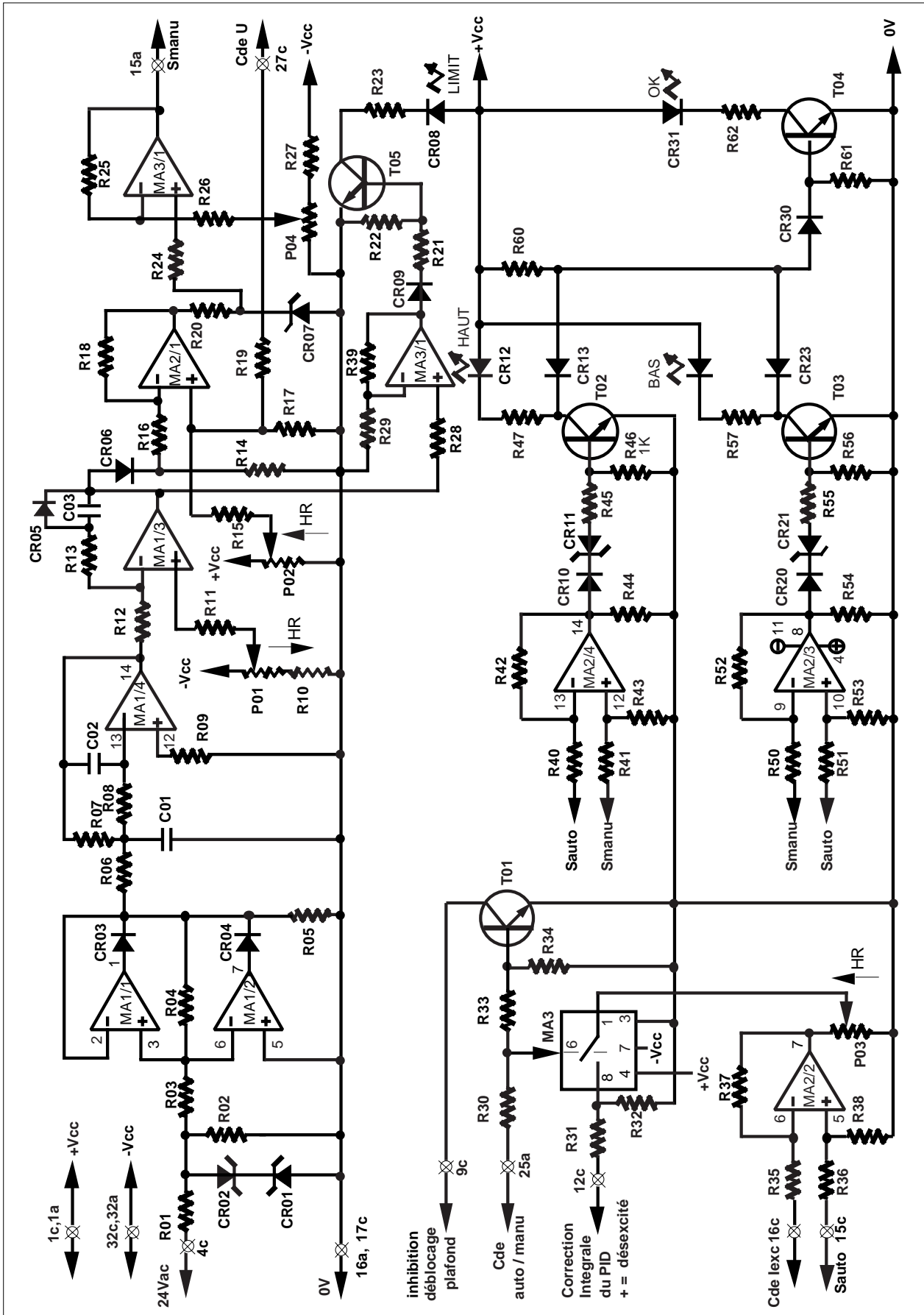

Principle diagram
Manual mode 1 card

1 - FUNCTIONAL

This card replace one conventional motorized potentiometer in "MANU" mode and sets the "MANU" channel output always equal to the "AUTO" one to allow the smooth switching between the "AUTO" and "MANU" riation at any load (follower in "AUTO" mode).

- Switch between the two modes is made by the external "AUTO / MANU" order (terminals 47,48)

- Jumps SW1 allows the choice between voltage output taken from U/F control of the sensing card or from a 5V fixed reference and the range is adjusted by means of potentiometer P03.

- Jumps SW3 and SW4 must be open for normal operation and closed for follower operation.

- Speed of the adjustment is controled by potentiometer P01 in manual setting and by P02 in follower operation. P02 acts as a delay between an "AUTO" output variation and the "MANU" output response.

- Two LED's (L1,L2) indicate the command orders + or - and two other LED's (L3,L4) indicates the maximum and minimum position of I_{field} settings

NOTE : When this card is fitted, the internal I_{field} setting (P02 of manual mode card) must be set to 0 or under the no load field value and an external setting potentiometer must not be used. The I_{field} setting is made only by mean of push-buttons on terminals 44, 45, 46.

2) ADJUSTMENTS

- P1 : Clock speed (Time delay in follower mode)
- P2 : Clock speed (range time in "MANU" mode)
- P3 : I_{field} range value
- SW1 : Voltage range fixed or U/F monitored
- SW3/4 : Normal (open) or follower (closed) operation

3 - INPUTS / OUTPUTS

Flat cable (BUS 64points)

- 23c : Cmd lower
- 22a : Cmd upper
- 25a : Cmd "AUTO / MANU"
- 11a : U/F voltage reference
- 16c : I_f reference set point input
- 15a : I_f reference set point input "MANU" channel
- 27c : I_{field} setting output to Manual mode card
- 30a : Maximum position of settings
- 1a,1c : +15Vdc regulated (Vcc)
- 32a,32c : -15Vdc regulated (Vdd)
- 16a,17c : Common ground (GND or 0V)

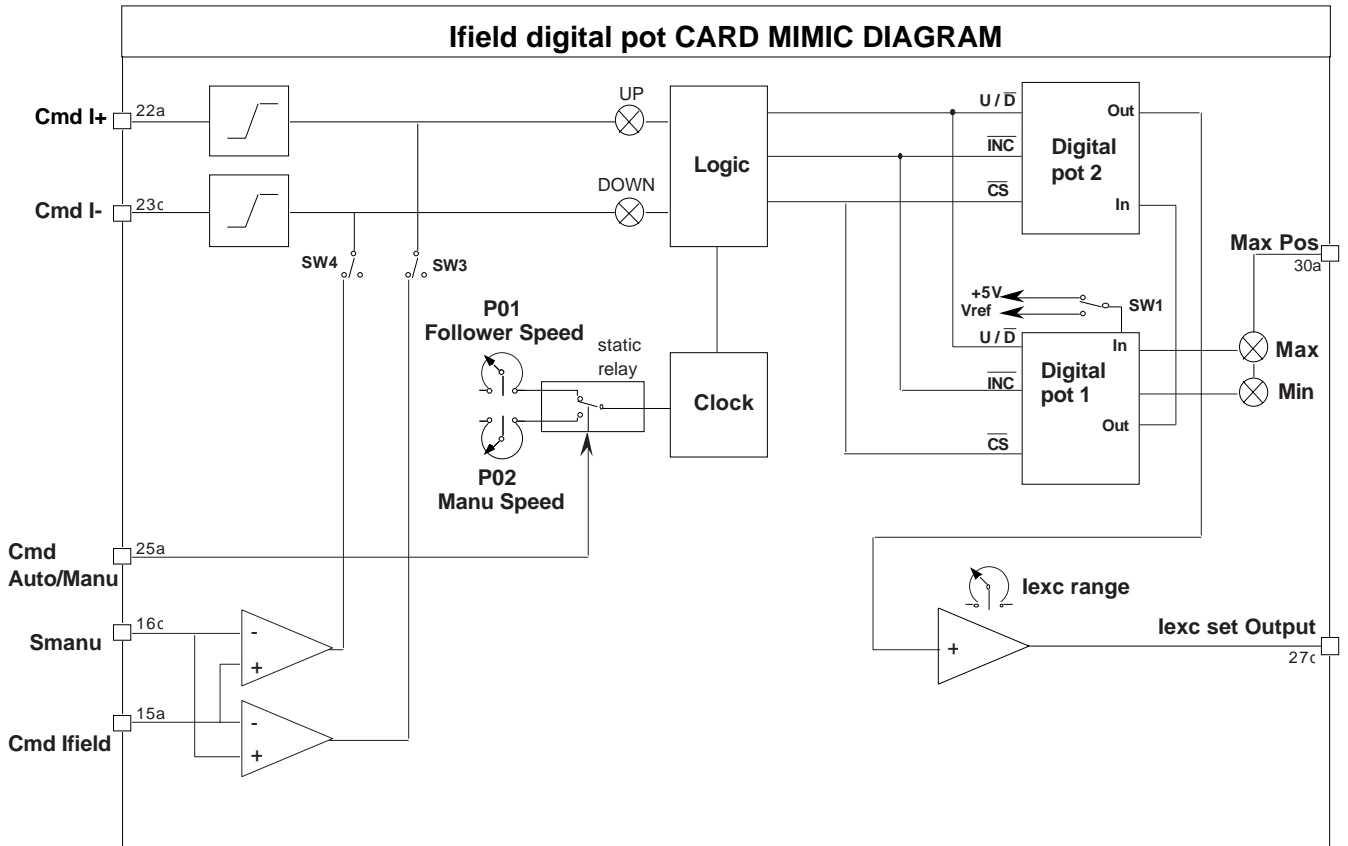

**FRONT VIEW
Digital pot Ifield**

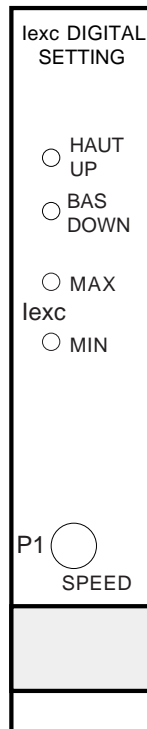

AVR Model R630

Digital pot I field Optional card

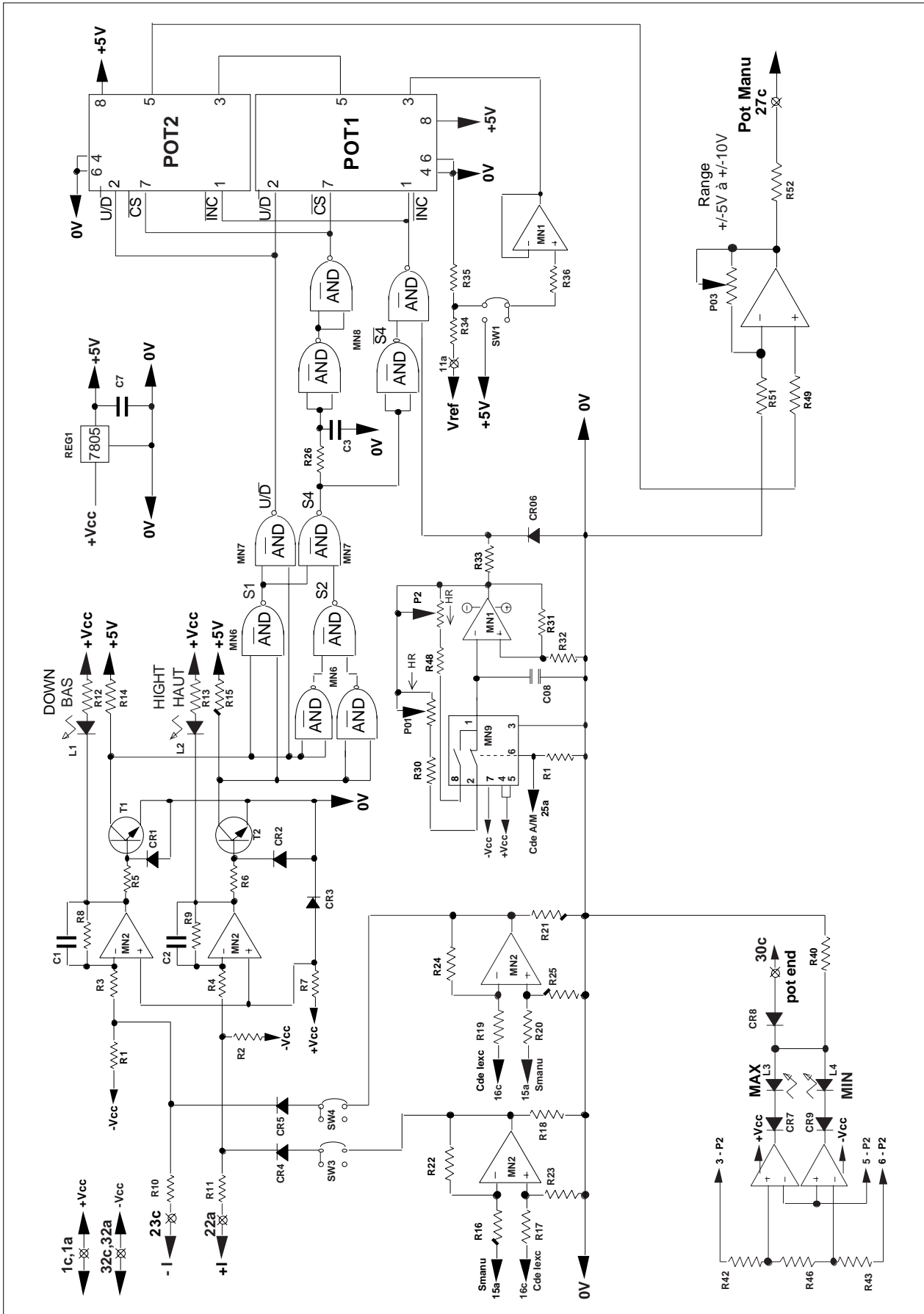

Principle diagram
I field digital potentiometer

AVR

Model R610 / R630

Mains P.F Regulation

Optional card

1 - DESCRIPTION

This card is used when the P.F or KVAR regulation is wanted not at the generator terminals but at the mains input. For this a P.F or KVAR sensor with 4-20mA output is necessary and it must be located at the place where the regulation must be made.

2 - FONCTIONAL

This card elaborates from setting informations and 4-20mA signal image of P.F (or KVAR) of the mains, the error voltage depending to the PID of the PID card.

- The error signal have an ajustable gain and can be versed depending of the 4-20mA sensor output.

- This kind of operation is indicated by the LED "L3" and by a contact (potential free) on the front connector.

- This operation is selected by mean of a contact on front connectort and will be active on coupling when contact between terminals 33, 34 of main terminals will be closed. If the contact on front connector remains open, the regulation (P.For KVAR) will be made at the generator output if it is closed, this is the 4-20mA information wich is regulate function of the internal settings (P2 or channel 2 4-20mA) or/and external by the front connector.

- If during operation, the measuring 4-20mA signal deseappears, control is automatically return to regulation on the generator output side and this failure is indicated by LED L1 ou L2 and by a contact on front connector.

- A second channel can be used as set point of the first channel or as a remote adjustment of voltage, P.F or KVAR on generator side. As on channel 1 if the 4-20mA deseappears, output is inhibited and indicated by LED L2.

- A field current limitation is given, active when a contact (front connector) is closed and indicated by LED L4. The limitatio is adjusted by P7 (Limit 2 set) and can be set between a maximum value preset by P7 on driver card and a minimum value preset by P8 on driver card.

- An signaling contact on the front connector gives (if they are used) the indication that one or more of the digital potentiometers are at maximum position .

3 - ADJUSTMENTS

Potentiometers

- P1 : Channel 1 range adjustment
- P2 : Reference set point channel 1
- P3 : Gain channel 1
- P4 : Channel 2 range adjustment
- P5 : Reference set point channel 2
- P6 : Gain channel 2
- P7 : Limit 2l adjustment

Jumpers - CV1 A

- : Channel 1 used
- CV1 B : Channel 1 not used
- CV2 A : Channel 1 used
- CV2 B : Channel 2 not used
- CV3 A : Non inverting error channel 1
- CV3 B : Inverting error channel 1
- CV4 A : Non inverting error channel 2
- CV4 B : Inverting error channel 2
- CV5 A : Channel 1 in 4-20mA regulation channel 1
- CV5 B : Channel 1 in voltage setting
- CV5 C : Channel 1 in generator P.F setting
- CV5 D : Channel 1 in generator KVAR setting
- CV6 A : Channel 2 in 4-20mA regulation channel 2
- CV6 B : Channel 2 in voltage setting
- CV6 C : Channel 2 in generator P.F setting
- CV6 D : Channel 2 in generator KVAR setting
- CV6 E : Channel 2 in channel 1 setting

4 - INPUTS / OUTPUTS

Flat cable (BUS 64points)

- 12c : Error output to PID
- 21a : Output to voltage setting
- 20c : Output to generator P.F setting
- 21c : Output to generator KVAR setting
- 30a, c : Digital pot at maximum position
- 1a,1c : Supply +15Vdc regulated (Vcc)
- 32a,32c: Supply -15Vdc regulated (Vdd)
- 16a,17c: Common ground
- 23a : Cmd + U or + P.F
- 24c : Cmd - U or - P.F
- 14c : Output of generator side P.F card
- 24a : P.F regulation order
- 26c : Limitation 2 output to driver card

Front connector (DB25 points)

- 13 : + 4-20mA input channel 1
- 25 : 4-20mA output channel 1
- 20 : 12V to external setting potentiometer ch 1
- 12 : External setting potentiometer cursor ch 1
- 24 : Ground to external setting potentiometer
- 11 : + 4-20mA input channel 2
- 23 : 4-20mA output channel 2
- 20 : 12V to external setting potentiometer (ch 2)
- 10 : External setting potentiometer cursor ch 2
- 22 : Ground to external setting potentiomete
- 9 : 4-20mA failure (NO)
- 21 : 4-20mA failure (NF)
- 8 : 4-20mA failure (Commun)
- 3 : Digital pot at max position (NO)
- 15 : Digital pot at max position (NF)
- 2 : Digital pot at max position (Common)
- 7,19 : Contact regulation ch 1 active (mains P.F)
- 14,1 : Contact limitation 2 active

LED

- L1, L2 : 4-20mA failure channel 1 or 2
- L3 : Channel 1 active
- L4 : lfield limitation 2 active

AVR Model R610 / R630

Mains P.F Regulation Optional card

MAINS P.F REGULATION CARD MIMIC DIAGRAM

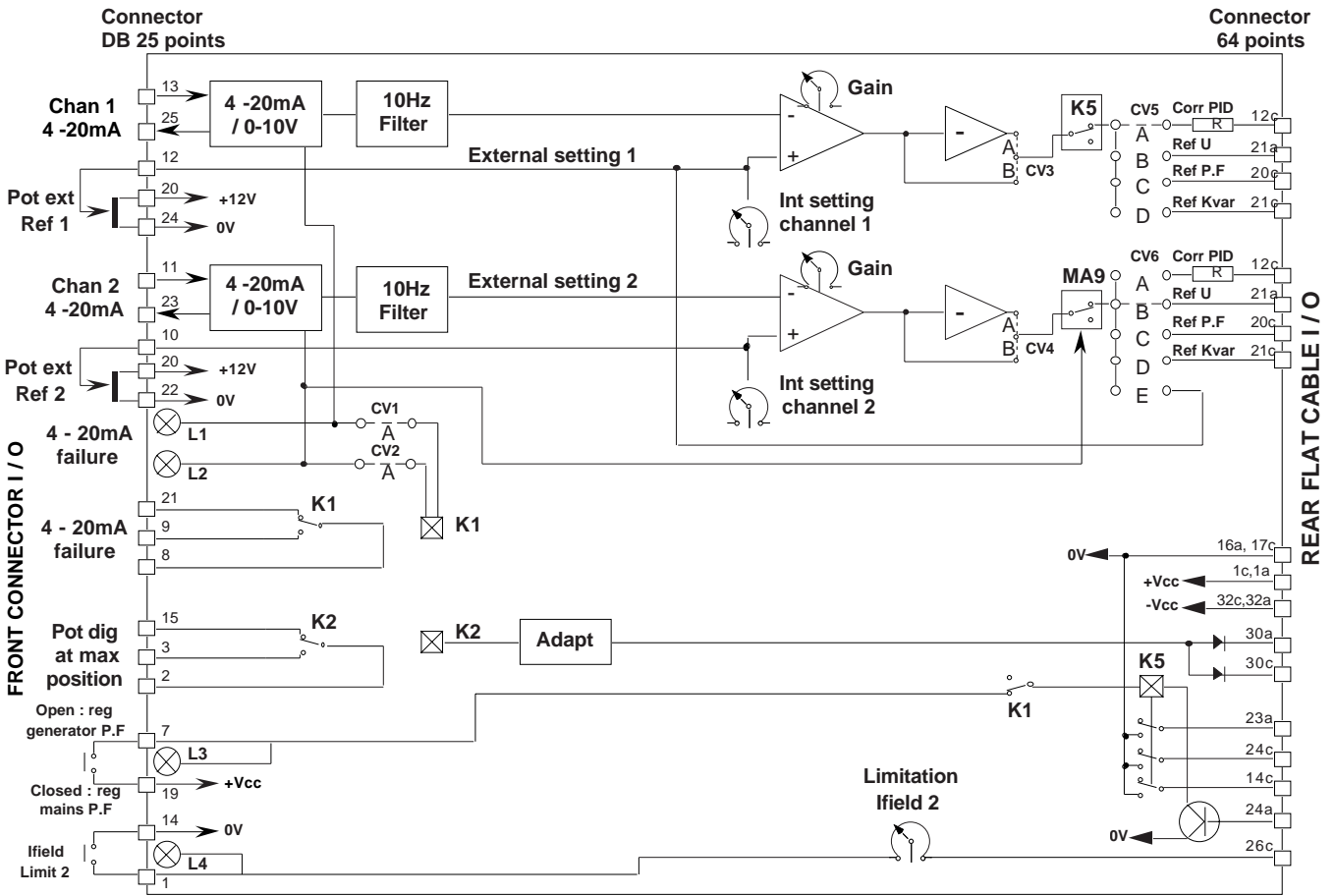

**FRONT VIEW
MAINS P.F REG**

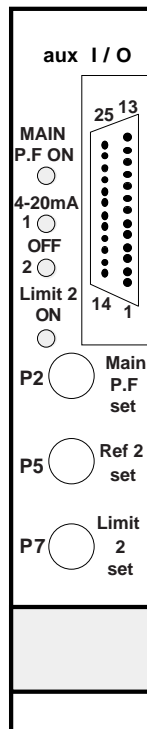

AVR Model R610 / R630

Mains P.F Regulation Optional card

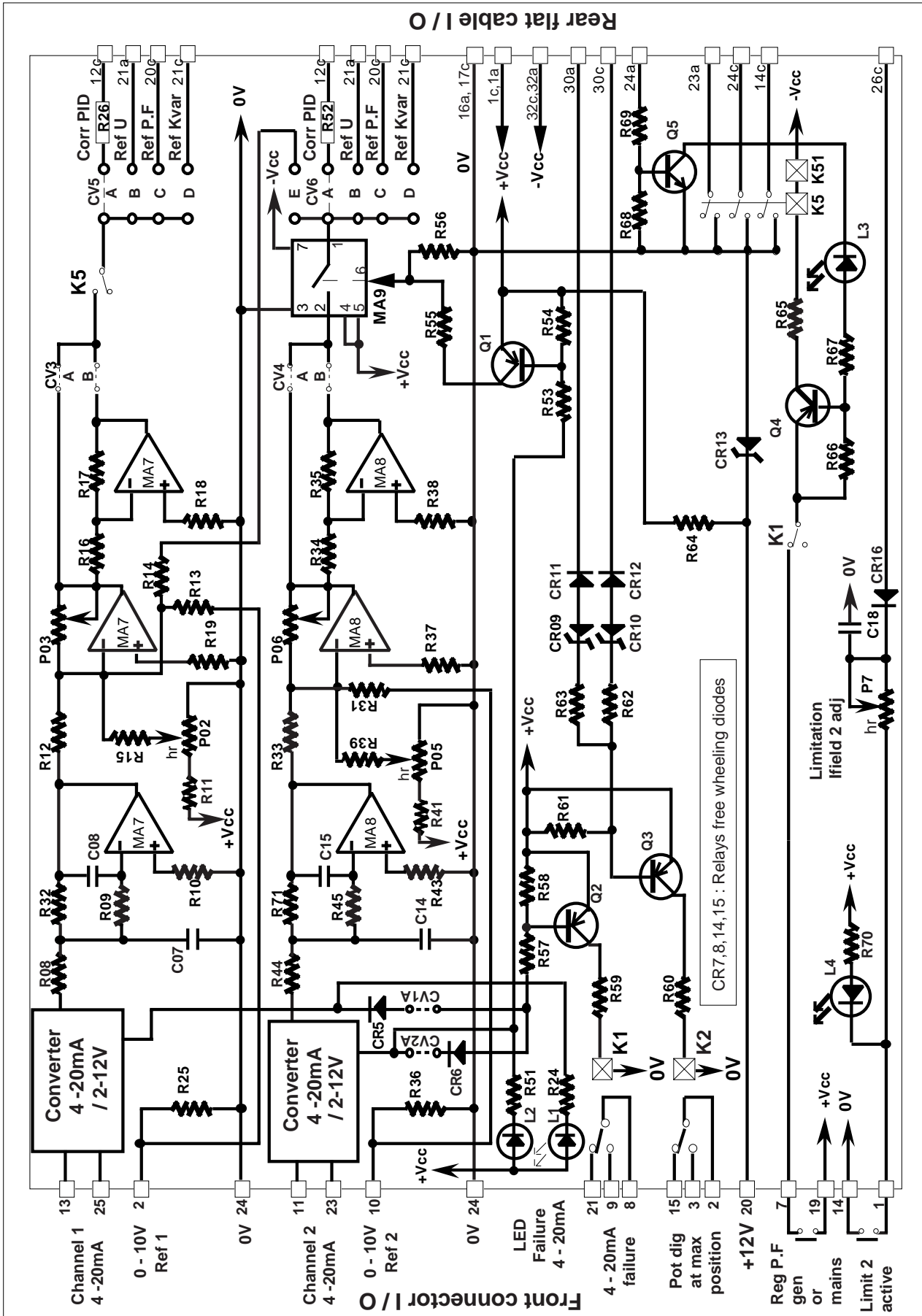

Principle diagram
mains P.F reg card

1 - FUNCTIONAL

- A voltage, image of the stator current of the machine, fed from the "ALTERNATOR I / O" card is rectified, filtered and compared to a reference voltage. The error signal ves a voltage correction which is added to the main PID input to maintain the stator current equal to the adjusted value.

- The reference voltage is applied with an initial ramp ajustable from 0,5 to about 4s.

- A front LED signals stator current limitation operation.

- When this card is used for soft-start operation, the AVR power transformer must be fed from a separate source during the start operation and can be switched on the nerator output when the voltage have reached the nominal value. The switching must be as fast as possible (by relay, not by manual switch).

2 - REGLAGES

- P1 : Stator current limit adjust. (about 2In to 4In)
- P2 : Ramp-up time adjust. (0,5 à 4s environ)
- P3 : Output signal gain

3 - INPUTS /OUTPUTS

- 9a : Stator current image input (1Vac for In)
- 1a,1c : +15Vdc regulated (Vcc)
- 32a,32c : -15Vdc regulated (Vdd)
- 16a,17c : Common ground (GND or 0V)
- 12c : Voltage correction output to PID.

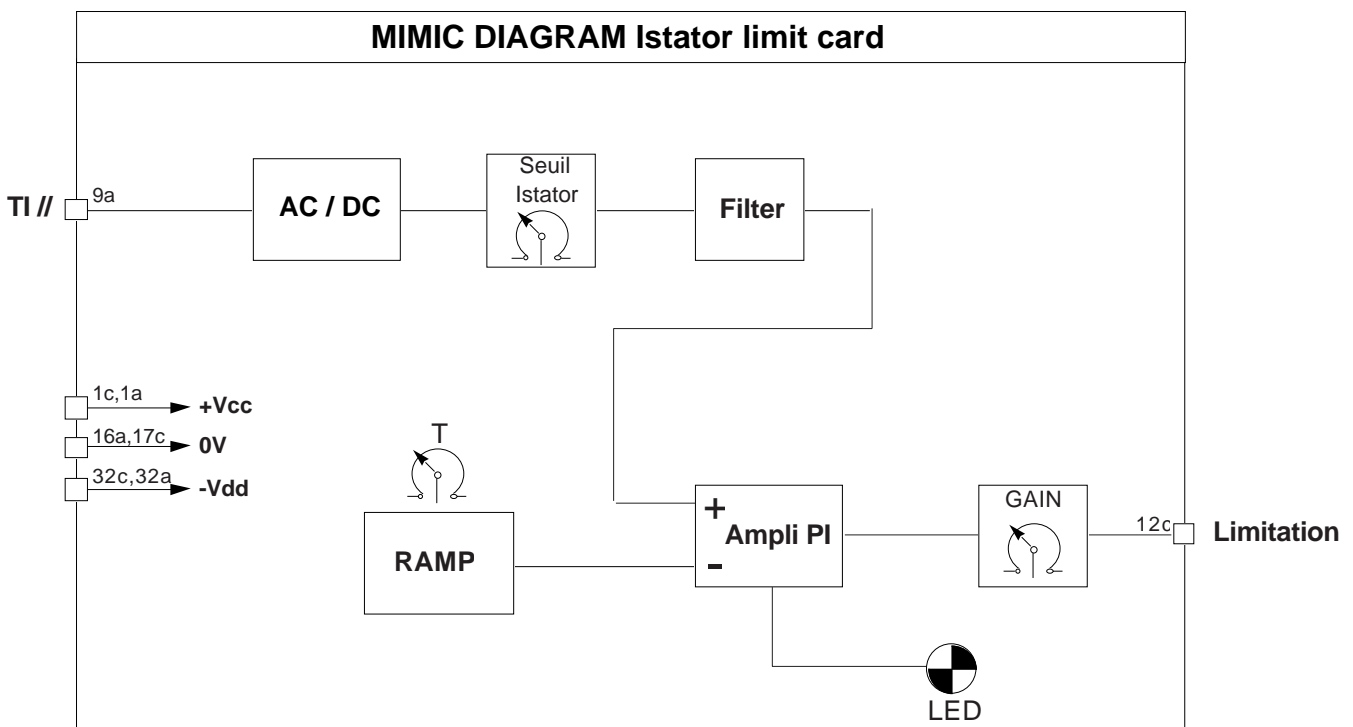

AVR Model R610 / R630

LIMIT Istator Optional card

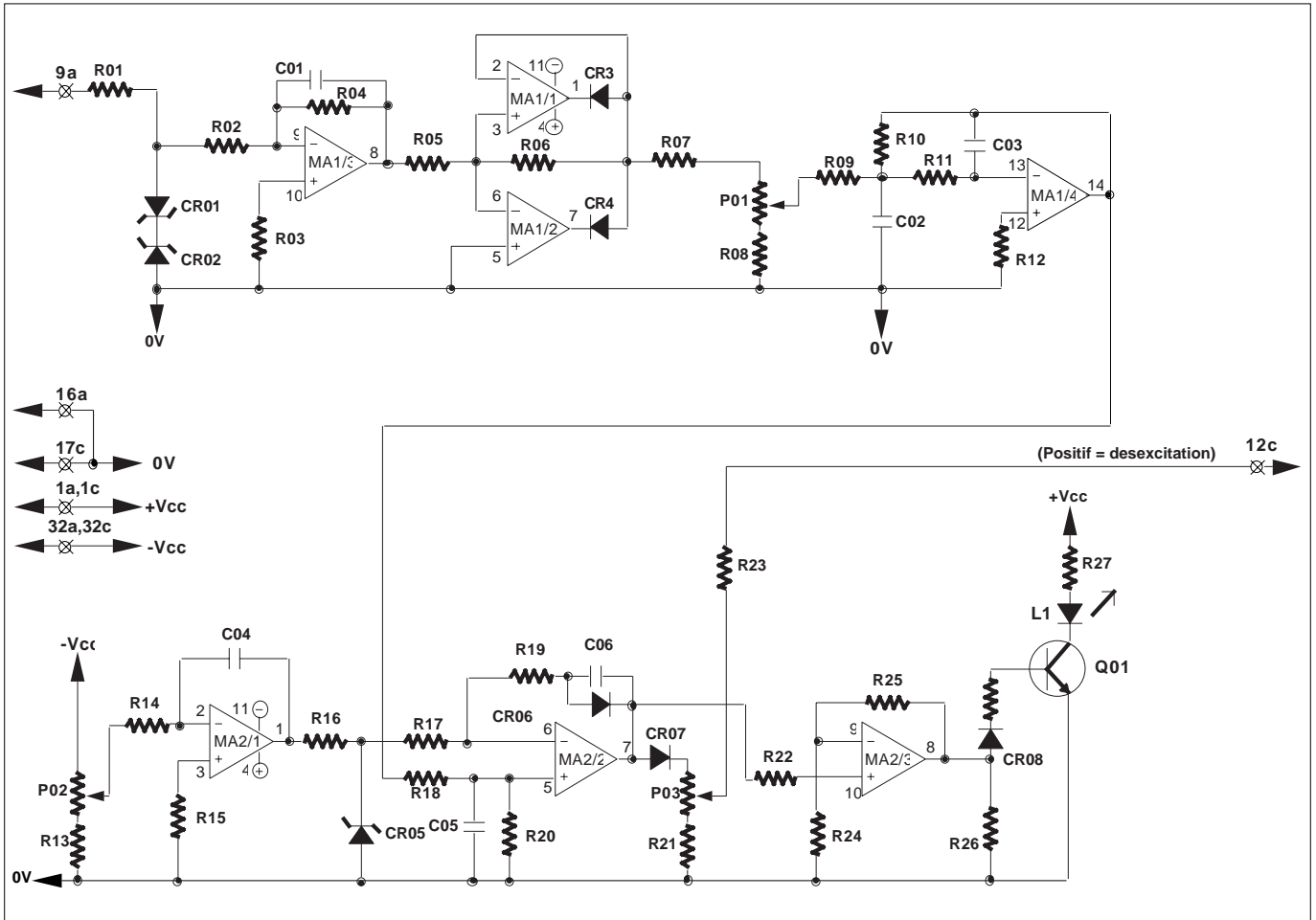

FRONT VIEW
Lim Istator card

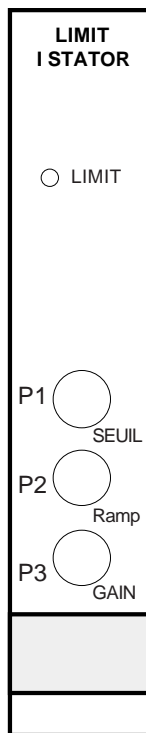

AVR MODEL R630 / PMG

START-UP

CAUTION

Never energize the AVR when the driver card is removed. An overvoltage can appear and the power transistor can be damaged.

1) STARTING WITH MANUAL MODE CARD

- For initial start-up, when a manual mode card was required and plugged inside the AVR, the best is to use the manual mode for testing the sensing wires between the generator and the AVR.
- For this it is necessary to have a manual mode card plugged in the AVR. If not, see directly §2.
- Short-circuit terminals 47 and 48 (AVR terminal block).
- Set the potentiometer P2 on manual card maximum CCW, start the prime mover up to the nominal speed.
- Turn slowly the potentiometer CW to obtain the nominal voltage.
- Check the presence and the value of the three phases at the AVR terminal block (terminals 1, 2, 3)
- Set the voltage to 5% above the nominal voltage.
- Check that the voltage between terminal 25 and 26 of the AVR terminal block is about one volt.
- If yes, remove the strap between terminals 47 and 48 of AVR terminal block.
- The voltage must reach the nominal value.
- Go to §3

2) STARTING WITHOUT MANUAL MODE CARD

- Start the prime mover up to the nominal speed..
- If the voltage does not appear, check wires between AVR and the generator field (terminals 5 and 6 of AVR), and the also the wires between AVR and PMG (terminals 17,18 and 19 of AVR). Check also the fuse (or breaker) on the terminal 17,18,19 of AVR terminal block.
- If the voltage is too high, check that the auxiliary voltage at the terminals 15 and 16 of AVR and the sensing voltages at the terminals 1, 2, 3 of the AVR terminal block are present.
- Adjust the nominal voltage with Vref (P5) of the sensing card for the middle position of the external voltage potentiometer (if used).

3) DE-ENERGIZING (optional)

- External contacts E01 must be used.
- E01 must be serie with PMG outputs (AVR power inputs) and are opened for de-energizing.

4) ADJUSTMENTS

- Refer also to card descriptions.
- The AVR is normally preset in factory.
- The nominal voltage can be set by Vref (P5) on sensing card. Fine adjustment can be made by an external voltage potentiometer (10K Ω), (terminals 21,22,23)
- If an adjustment must be moved, note carefully the original setting for resetting in case of problems.
- If the strap V/Hz of sensing card is on kV/Hz position, the original setting is V/Hz and can be changed between V/Hz and 2V/Hz.
- The stability is adjusted with the machine in factory . If necessary, the response time can be changed by the setting of potentiometer P4 of PID card.
- Other settings are difficult to adjust without specific electronics equipments. It is better to not change them.

5) FIELD FLASHING

- Permanent Magnet Generator does not need a field flashing.

6) PARALLEL OPERATION(1F)

- The generator voltages must be as equal as possible.
- Same for the droop. If it is not possible to measure it, set the potentiometers P1 of the sensing cards all in the same position. (middle set for example). If the droop setting is made from cos ϕ /KVAR card (when used), see notice NT 1950080.
- The reactive currents (KVAR) must be shared, immediately after coupling, even the KW are not shared.
- If, immediately after coupling, the current increases abnormally, check if the parallel CT wires are not reversed. (9 et 10 of AVR terminal block)
- If the coupling is OK but if when the load increases, the cos ϕ or the current have an abnormal value, check that the sensing phases at the input of the AVR are right connected. (U, V, W respectively to the terminals 1, 2, 3 if clockwise rotation or W, V, U, if counter clockwise rotation)

AVR MODEL R630 / PMG

START-UP

7) PARALLEL WITH THE MAINS (2F)

- The generator and mains voltages must be as equal as possible. (see §8 if MAIN I/O card is used). **The contact between terminals 33, 34** of AVR terminal block **must be closed at the same time as the coupling** and will remain closed as long as the generator is connected to the mains.

It will be open when parallel between generators.

- If, immediately after coupling, the current increases abnormally, check if the parallel CT wires are not reversed. (9 et 10 of AVR terminal block)

- If the coupling is OK but if when the load increases, the $\cos\phi$ or the current have an abnormal value, check that the sensing phases at the input of the AVR are right connected. (U, V, W respectively to the terminals 1, 2, 3 if clockwise rotation or W, V, U, if counter clockwise rotation)

- The PF value is normally factory set to 0.8 . It can be adjusted by mean of potentiometer P2 on $\cos\phi$ /KVAR card or by mean of an external potentiometer (10K Ω -1W) connected to AVR terminal block (27,28,29)

- If the KVAR regulation is required terminals 48 and 53 must be short-circuited and the KVAR can be set by mean of potentiometer P1 on $\cos\phi$ /KVAR card or by mean of an external potentiometer (10K Ω -1W) connected to AVR terminal block (30,31,32)

-For droop setting, see notice NT 1950080.

8) VOLTAGE EQUALISATION (3F)

- The following procedure must be made one time to take account of the mains transformer primary/secondary ratio.

- At no load and mains voltage present at terminals 12,13,14 of the AVR terminal block.

- Short circuit terminals 35,36 of the AVR terminal block

- Adjust P1 of MAIN I/O card to have generator and mains voltage as equal as possible.

- Remove the strap between terminals 35,36 of the AVR terminal block.

- The initial setting is made.

In normal operation the contact between terminals 35,36 of the AVR terminal block must be closed with synchronizer operation and can be opened after coupling.

9) MANUAL OPERATION (if used)

-If a manual mode card is used, it is possible to control directly the field current of the generator.

- In automatic mode, adjust the potentiometer P2 on manual mode card to have the LEDs "HIGHT" and "LOW" off and the LED OK lighting. At this time the manual setting is equal to the automatic channel control.

- Short-circuit the terminals 47,48 of the AVR terminal block gives control to the manual channel and the field current is adjusted by potentiometer P2 and/or by an external optional potentiometer (10K Ω -1W) connected to the terminals 30,52,23 of the AVR terminal block cursor on 52 and hot point on 30.

- This mode can be used when initial start-up of the generator, to make test after problems or when operating with the mains. It cannot be used when solo operation because it is not possible to follow fast load variations.

- When coupling with the mains on load, if trip of the generator occurs, an overvoltage may occurs due to the fact that the field current setting is too high regarding the load of the generator. On this case, an internal circuit of the card decreases the field current to limit the overvoltage approximatively to 110% of nominal. LED "LIMIT" on front of the card will light. The setting of field current must be reset manually to the no load value and the LED "LIMIT" will switch off.

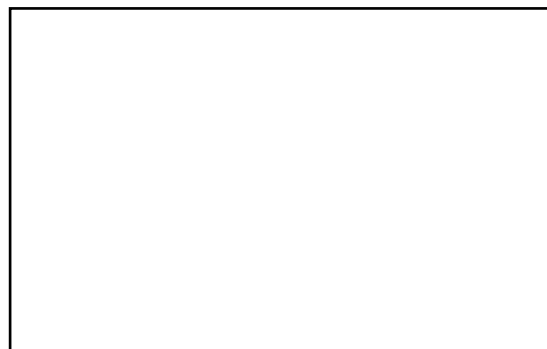

MOTEURS LEROY-SOMER 16015 ANGOULÊME CEDEX - FRANCE

RCS ANGOULÊME N° B 671 820 223

S.A. au capital de 131 910 700 F

<http://www.leroy-somer.com>