

△ 采用生态镀锌

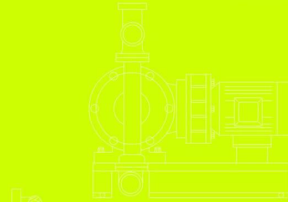

上乘品质 上武流体 上乘品质 上武流体 上乘品质 DBY电动隔膜泵
DBY ELECTRIC DIAPHRAGM PUMP

隔膜泵专业制造商
DIAPHRAGM PROFESSIONAL
MANUFACTURER



上乘品质 上武流体 上乘品质 上武流体 上乘品质 上武流体

浙江上武流体科技有限公司
地址：浙江省永嘉县六秀工业区
服务热线：0577-67188823
0577-67188835
0577-67188837
传真热线：0577-67188873

浙江上武流体科技有限公司
Zhejiang Shang Wu Fluid Technology Co., Ltd.

目录 CONTENTS

产品概述 Product Description	01
主要用途 Usa The Field	01
安装方式 Znstallation Method	01
性能特点 Function	02
工作原理 Working Principle	02
结构原理图 Structural Drawing	03
涡轮式性能参数 Performance Paramete	04
膜线式性能参数 Performance Paramete	04
涡轮式安装尺寸表 Drawing Of Setting Data	05
膜线式安装尺寸表 Tables Of Setting Data	06
膜线式(卧式)安装尺寸图 Drawing Of Setting Data	06
膜线式(卧式)安装尺寸表 Tables Of Setting Data	06
膜线式(卧式)安装尺寸图 Drawing Of Setting Data	07
特性曲线图 Characteristic Curve	08
材料特性 Characteristic Of Diaphragm	08
正确选用隔膜泵 Proper Selection Diaphragm Pumps	09
注意事项 Note	09

DBY电动隔膜泵系列 DBY ELECTRIC DIAPHRAGM PUMP SERIES

产品概述 Product Description

DBY电动隔膜泵最新的一种泵类。近年来，由于在隔膜材质上取得了突破性的进展，国际上越来越多的工业化国家采用此种型式隔膜，取代部分离心泵、螺杆泵，来应用于石化、陶瓷、冶金等行业。目前生产的电动隔膜泵产品设计与参考美国ABEL公司特机。DBY型隔膜泵适用于压力：即出口压力 $\leq 3kgf/cm^2$ 的情况。

DBY electric diaphragm pump is a kind of novel of the pump. In recent years, due to the diaphragm materials made in breakthrough progress, more and more industrialized countries using this type of pump, replacing part of centrifugal pump, screw, used in metallurgy, petrochemical, ceramics, etc. current production of electric diaphragm pump product design, the prototype of ABEL company DBY type diaphragm pump pressure, namely applicable than outlet $\leq 3kgf/cm^2$ pressure.

主要用途 UsaThe Field

1. 泵吸花生酱、泡菜、土豆泥、红肠、巧克力、啤酒花、糖浆等；
2. 泵吸油漆、腻子、胶水、粘合剂等；
3. 泵吸各种浆、浆、浆液及膏状物等；
4. 泵吸各种酸、碱、溶剂、清洗液等；
5. 泵吸各种毒、易燃、易爆液体等；
6. 泵吸各种污水水渣泵及泵等；
7. 泵吸各种煤浆、泥浆、泥膏混合物等；
8. 作为各种液体少量给料的前置设备；
9. 可输送最高温度的介质150℃
10. 作为各种连续机前级增压装置
11. 热水回收及循环
12. 各种特殊介质的效果

1. The pump can suck the peanut, pickles, tomato, slurry, red sausage, chocolate, hops and syrup etc.
2. The pump can suck the paint, pigment, glue and adhesive etc.
3. The pump can suck various greazed slurries of tile, porcelain, brick and chinaware etc.
4. The pump can suck various grinding materials, corrosive agent and olean the oil dirt etc.
5. The pump can suck various toxin and flammable or volatility liquid etc.
6. The pump can suck various wedge water, cement slurry and mortar etc.
7. The pump can suck various strong acid, alkali and corrosive liquid etc.
8. It can be used as a front-step transmission device of the solid and liquid separation equipment.
9. Can transport high temperature medium 150℃.
10. And as all kinds of filler press former sand pressure device.
11. And hot water recycle and circulation.
12. And various special medium suction pump.

电动隔膜泵系列 Electric Diaphragm Pump Series



流体转移
Fluid Transfer

DBY电动隔膜泵(涡轮式)
electric diaphragm pump (turbine type)

DBY电动隔膜泵(膜线式)
electric diaphragm pump (membrane type)

安装办法 Znstallation Method



将液体A由膜送到B的方法可以照此法
This method can be adopted when sending
the liquid from vessel A to vessel B



高黏稠液体可采用此方法将液位提高，使液体容易抽出
For liquids of high viscosity, this method can be adopted
to enhance the liquid level and make it easy to pump out
the liquid materials.

DBY电动隔膜泵系列
DBY ELECTRIC DIAPHRAGM PUMP SERIES

性能特点Function

DBY电动隔膜泵能抽送腐蚀性液体，又能抽送一些不易流动的介质，采用新型摆线针轮减速机传动，通过曲轴带动传动机构带动隔膜作往复运动，使工作容积发生周期性变化从而不停地吸入和排出，具有自吸泵、潜水泵、屏蔽泵、定流量和连续泵等输送机械的好多优点。

DBY electric diaphragm pump can pumping flow of liquid, and not the medium flow conveying some, adopting new cycloidal reducer drive through the crankshaft slide block double diaphragm drives a demerit for reciprocating motors, make working volume changes will occur alternately liquid constantly inhaling and exhaling. Self-priming pumps, with submersible pumps, shielding, mud pump and impurities pump etc many advantages.

1. 不需灌引水，吸程高达5m，扬程达30m。
 2. 通过性能好，直接打10mm以下的颗粒，泥浆等可以毫不费力地通过。
 3. 由于隔膜泵密封性能好和传动轴密封好，所以不会发生介质的泄露，且泵本身无轴封，使用寿命大大延长。
 4. 根据不同介质，隔膜分为氟橡胶、氯磺酸、丁腈橡胶、四氟橡胶等，可以满足不同用户的要求。
 4. 泵体介质流道部分，根据用户要求，分为铸铁、铝合金、不锈钢、衬氟。电机分为普通型和防爆型两种。
- 1.It's unnecessary to pour the drawing water, the suction lift reaches 7m height, the delivery lift reaches 30m.
2.Through the performance is good, directly in the particle, mud 10mm below such can easily.
3.Because of the diaphragm pumps will be transfer medium and give a separate transmission medium, so never to reveal. And pump shaft sealing, use is itself greatly prolonging life. According to different medium, the diaphragm into a synthetic rubber, rubber, butadiene acrylonitrile rubber, four fluorine rubber, which can satisfy the requirements of different customers.
4.Pump body medium flows, according to user requirements, iron, aluminum alloy, stainless steel, fluorine, motor is divided into general type and explosion-proof type two kinds.

工作原理Working Principle

电机(4)通过齿轮(3)带动左右两柱塞(2)一前一后进行运动，在左右两个柱塞内，装上下四个单向球阀(1)，隔膜的运动，造成工作腔内的容积的变化，迫使四个单向球阀交替的开启和关闭，从而将液体不断地吸入和排出。

Motor (4) through the gear box (3) above the diaphragm plunger to drive around the ends (2) one after the other to reciprocate. In the left and right pump chamber, upper and lower four-way valve is equipped with (1), the movement of the diaphragm, Causes a change in volume of the working chamber, forcing the four-way valve to open and closed alternately, so that the liquid suction and discharge continuously.

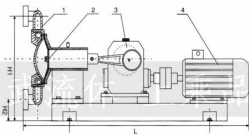

DBY电动隔膜泵系列
DBY ELECTRIC DIAPHRAGM PUMP SERIES

结构原理图 Structural drawing

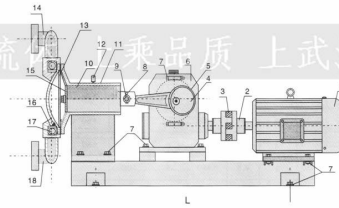

编号 No	名称 Designation	材质 Material	数量 QTY
1	电机 Motor		1
2	联轴器 Coupler	HT200	2
3	六角弹性块 Hex Elastic Block	氟丁橡胶Neoprene	1
4	偏心轴 Eccentric	HT250	2
5	连杆 Connecting	ZG	2
6	减速机 Reduction Box		1
7	螺栓 Bolts	Q235-A	36
8	开口销 Split Cotter	Q235-A	2
9	活塞销 The Piston Pin	A3	2
10	活塞 The Pistons	无缝对接厚壁管Seamless tube welding ends	2
11	缸套 Cylinder	HT200	2
12	密封 Oil Cup		2
13	隔膜 The Diaphragm	丁腈橡胶 氟丁橡胶Butadiene acrylonitrile rubber neoprene	4
14	出水管 Outlet Pipe	不锈钢OCr18Ni9 镀锌HT200 铝合金ZL104	1
15	压板 Linking Piece	A3	4
16	球座 Ball Seat	丁腈橡胶 氟丁橡胶Butadiene acrylonitrile rubber neoprene	4
17	球 Ball	丁腈橡胶 氟丁橡胶Butadiene acrylonitrile rubber neoprene	4
18	进水管 Inlet Pipe	不锈钢OCr18Ni9 镀锌HT200 铝合金ZL104	1

DBY电动隔膜泵系列
DBY ELECTRIC DIAPHRAGM PUMP SERIES

涡轮式性能参数 Performance Paramete

型号 Model	流量 Discharge (m³/h)	扬程 Head (m)	出口压力 Exit pressure (kgf/cm²)	吸程 Sucked lift (m)	转速 Speed (r/min)	电机功率 Electric power (KW)	使用温度 Use Temperature	进出口尺寸 Import and export Size (mm)		重量 Weight (kg)
								球铁 HT200	不锈钢 OCr18Ni9	
DBY-10	0.5	0-30	3	3	1450	0.37	100	150	3/8"丝扣Threaded	50
DBY-15	0.75	0-30	3	3	1450	0.37	100	150	1/2"丝扣Threaded	50
DBY-25	3.5	0-30	3	4	1450	1.5	100	150	1"丝扣Threaded 25法兰Flange	170
DBY-40	4.5	0-30	3	4	1450	2.2	100	150	1 1/4"丝扣Threaded 40法兰Flange	180
DBY-50	6.5	0-30	3	4.5	1450	4	100	150	50法兰Flange	400
DBY-65	8	0-30	3	4.5	1450	4	100	150	65法兰Flange	400
DBY-80	16	0-30	3	5	1450	5.5	100	150	80法兰Flange	610
DBY-100	20	0-30	3	5	1450	5.5	100	150	100法兰Flange	610

注：产品详情请参阅目录图片片 Note: product samples, please refer to the directory page images

摆线式性能参数 Performance Paramete

型号 Model	流量 Discharge (m³/h)	扬程 Head (m)	吸程 Sucked lift (m)	电机功率 Electric Power (kw)	使用温度 Use Temperature	进出口尺寸 Import and export Size (mm)			重量 Weight (kg)
						球铁 HT200	不锈钢 OCr18Ni9	衬氟 Fluorine	
DBY-10	0.5	40	3	0.55	100	150	-	3/8"丝扣Threaded	50
DBY-15	0.75	40	3	0.55	100	150	-	1/2"丝扣Threaded	50
DBY-25	3.5	40	4	1.5	100	150	150	1"丝扣Threaded 25法兰Flange	170
DBY-40	4.5	40	4	1.5	100	150	150	1 1/4"丝扣Threaded 40法兰Flange	170
DBY-50	6.5	40	4.5	2.2	100	150	150	50法兰Flange	300
DBY-65	8	40	4.5	2.2	100	150	150	65法兰Flange	300
DBY-80	16	40	5	3	100	150	-	80法兰Flange	400
DBY-100	20	40	5	3	100	150	-	100法兰Flange	400

注：产品详情请参阅目录图片片 Note: product samples, please refer to the directory page images

DBY电动隔膜泵系列
DBY ELECTRIC DIAPHRAGM PUMP SERIES

涡轮式安装尺寸 Drawing of setting data

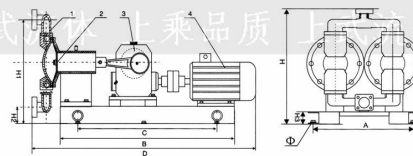

涡轮式安装尺寸表 Tables of setting data

型号 Model	A	B	C	D	H1	H2	H3	H	φ
DBY-10	280	810	410	650	340	78	78	340	φ12×4
DBY-15	280	810	410	650	340	78	78	340	φ12×4
DBY-25	300	750	550	1100	480	50	100	540	φ14×4
DBY-40	300	750	550	1100	490	50	100	540	φ14×4
DBY-50	335	1160	800	1510	700	85	140	720	φ16×4
DBY-65	335	1160	800	1510	700	85	140	720	φ16×4
DBY-80	425	1350	570	1690	900	96	160	900	φ18×4
DBY-100	425	1350	570	1690	900	96	160	900	φ18×4

DBY电动隔膜泵系列
DBY ELECTRIC DIAPHRAGM PUMP SERIES

摆线式安装尺寸图 Cycloidal Drawing Of Setting Data

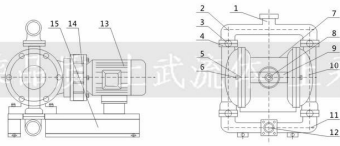

图一

主要零件名称及材料Name Of Main Parts And Materials				主要零件名称及材料Name Of Main Parts And Materials			
编号No.	名称Name	材质Texture	数量Quantity	编号No.	名称Name	材质Texture	数量Quantity
1	出口弯头 Export Links	不锈钢 Stainless Steel	1	9	活塞销 Piston pin	碳钢 Carbon Steel	1
2	出口接头 Outlet Elbow	不锈钢 Stainless Steel	2	10	壳体 Pump	不锈钢 Stainless Steel	2
3	密封球 Seal Ball	四氟 PTFE	4	11	进口弯头 Imported elbow	不锈钢 Stainless Steel	2
4	密封垫 Seal Seat	四氟 PTFE	4	12	进口三通 Imported links	不锈钢 Stainless Steel	1
5	隔膜片 Diaphragm	四氟橡胶 PTFE Rubber	6	13	电机 Motor		1
6	压紧螺钉 Plate Screws	不锈钢 Stainless Steel	2	14	减速机 Reducer		1
7	中间轴 Internals/Shaft	铸铁 Cast Iron	1	15	底座 Foot	槽钢 Channel	1
8	离心泵带电机 W/B Eccentric Bearing	碳钢 Carbon Steel	1				

摆线式安装尺寸表 Cycloidal Tables of setting data

型号Model	P	B	K	L1	L2	M	N	H	Q	F	A
DBY-15	180	284	250	580	240	175	265	245	50	10	110
DBY-25	155	260	430	400	650	300	120	480	230	65	180
DBY-40	155	260	430	400	650	300	120	480	230	65	180
DBY-50	175	340	570	500	800	315	140	770	265	75	220
DBY-65	175	340	570	500	800	315	140	770	265	75	220
DBY-80	185	450	670	650	940	420	140	920	350	110	270
DBY-100	185	450	670	650	940	420	140	920	350	110	270

○详见图二

DBY电动隔膜泵系列
DBY ELECTRIC DIAPHRAGM PUMP SERIES

安装尺寸图 Installation Dimensions

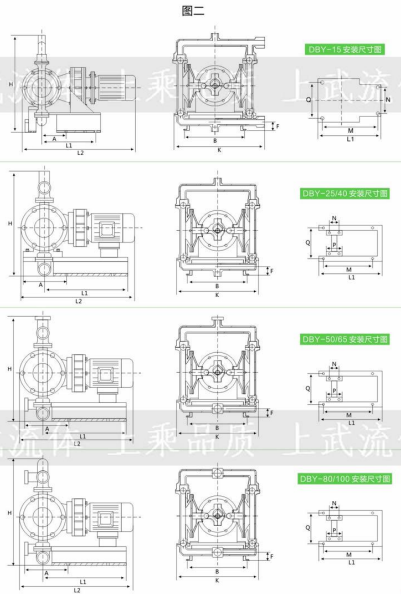

DBY-15 安装尺寸图

DBY-25/40 安装尺寸图

DBY-50/65 安装尺寸图

DBY-80/100 安装尺寸图

DBY电动隔膜泵系列
DBY ELECTRIC DIAPHRAGM PUMP SERIES

特性曲线图 Characteristic curve

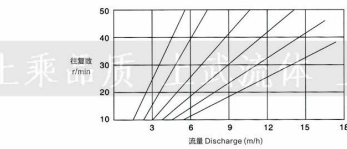

材料特性 Characteristic of diaphragm

介质种类 Media types	丁腈橡胶 Nitrile rubber	氟丁橡胶 Neoprene	聚四氟乙烯 Fluorine rubber	聚四氟乙烯 Teflon	食品级橡胶 Food Rubber
发烟硝酸 Fuming nitric acid	×	×	△	△	△
浓硝酸 Concentrated nitric acid	×	×	△	△	△
浓硫酸 Strong sulfuric acid	×	×	△	△	△
浓氢氟酸 Concentrated hydrofluoric acid	×	△	△	△	△
浓磷酸 Strong phosphoric acid	×	△	△	△	△
冰醋酸 Acetic Acid Glacial	×	×	×	△	△
浓氢氧化钠 Strong Sodium Hydroxide	△	△	△	△	△
无水氨 Anhydrous ammonia	△	△	△	△	△
稀硝酸 Dilute nitric acid	×	×	△	△	△
稀硫酸 Dilute sulphuric acid	△	△	△	△	△
稀盐酸 Dilute hydrochloric acid	×	×	×	△	△
稀磷酸 Dilute phosphoric acid	×	×	△	△	△
稀氢氧化钠 Dilute disodium Hydroxide	△	△	△	△	△
氨水 Ammonia water	△	△	×	△	△
苯 Benzene	×	×	△	△	△
汽油 Gasoline	△	△	△	△	△
石脑油 Oil	△	△	△	△	△
四氯化碳 Four oxidation carbon	△	△	△	△	△
二硫化碳 Carbon disulfide	△	△	×	△	△
乙醇 Ethanol	△	△	△	△	△
异丙醇 Acetone	×	×	×	△	△
硝基 Chloro	×	×	△	△	△
乙烷 Acetylene	×	×	×	△	△
乙苯 Ethylbenzene	×	×	×	△	△
丙酮 ACETONE/ETYL	△	△	×	△	△
丁醇 Butanol	△	△	△	△	△
丁二烯 Butadiene	△	△	△	△	△
苯乙烯 Styrene	×	×	△	△	△
醋酸乙酯 Dilute ethyl	×	×	×	△	△
醇 Ethyl	×	×	×	△	△

注：△—————更长寿命，△—————普通寿命，X—————不可用。本表仅从耐腐蚀性考虑，因聚四氟乙烯弹性较差，故实际使用寿命压力、泵用负载等因素影响而降低。食品级橡胶用于食品行业。
Note: △—longer life, △—ordinary life, X—not applicable. The table only considers anticorrosion. As an elasticity of PTFE is relatively low, the actual service life may be different under the influence of pressure, pump travel, impurities and other factors. Food rubber is specially used for food and beverage industries.

DBY电动隔膜泵系列
DBY ELECTRIC DIAPHRAGM PUMP SERIES

正确选用隔膜泵 Proper selection diaphragm pumps

本隔膜泵的主要部件是隔膜，正确选用隔膜可以达到事半功倍的目的，用户订货时请注明输送介质的性质，以便出厂时配备不同隔膜。

一般隔膜如下列几种：

- 一、丁腈橡胶，主要用于油类场合。
- 二、氟丁橡胶5031#本厂特制，主要用于各种酸类、碱类。
- 三、氟橡胶6021#本厂特制，主要用于高温150℃，耐半苯耐蚀性，性价比比其他隔膜高。
- 四、四氟隔膜，主要用于浓硫酸、强碱、溶剂等。
- 五、食品级橡胶，有用于食品饮料的输送。

The main part of the diaphragm pump is the diaphragm. Correct selection of the diaphragm can get twice the result with half the effort. When placing orders, the user shall note characters of media to be transported, so that different diaphragms can be provided when the product is delivered. Generally, the diaphragm types are shown as follows:

1. NBR diaphragm, mainly used for oil resistant occasions.
2. Neoprene 5031# specially manufactured by our factory, mainly used for various acids and alkalis.
3. Fluorine rubber 6021# specially manufactured by our factory, mainly used for high temperature 150°C, to luene resistance and corrosion resistance. But its price is higher than other diaphragms.
4. PTFE diaphragm, mainly used for various strong acids, strong alkalis, solvents, etc.
5. Food rubber, specially used for transporting food and beverage.

注意事项 Note

1. 泵出口严禁安装阀门，如必须装阀门，要在出口安装安全阀门，工作压力不得超过4公斤，以免造成损失。
 2. 泵应及时加油，保持隔膜泵系统正常运转。
 3. 泵在使用中环境温度应小于40℃，电机温度不得超过75℃。
 4. 输送的介质其温度应在泵允许范围内。
 5. 对于输送液体为粘状或结晶的介质时，使用后应及时清洗泵内积物，以免再开时堵塞。
1. No valve is permitted to be installed at the outlet of the pump. If it is necessary to install a valve, a safety valve shall be installed at the outlet. The working pressure shall not exceed 4kg; otherwise, damage may be caused.
2. Please add the oil in time to maintain normal operation of the lubricating system.
3. During the use of the pump, the ambient temperature shall be less than 40°C and the motor temperature shall not exceed 75°C.
4. The transported media and temperature shall be within the allowable range of pump materials.
5. If the liquid to be transported is the medium that will easily deposit or crystallize, please clean the pump and discharge the accumulated things in the pump after the use, so as to avoid any damage when restarting the pump.

产品现被广泛应用于环保、给排水、建筑、石油、化工、医药、电力等领域，树立了隔膜泵良好口碑
PRODUCTS ARE WIDELY USED IN ENVIRONMENTAL PROTECTION, TO FIELD DRAINAGE, CONSTRUCTION, PETROLEUM, CHEMICAL, PHARMACEUTICAL, POWER, ETC., AND ESTABLISH A GOOD REPUTATION DIAPHRAGM.

严谨的工作态度，科学的流体作业
THE RIGOROUS WORK ATTITUDE, SCIENTIFIC FLOW OPERATION

高水准的检测中心，高素质的检验团队
HIGH LEVEL OF TEST CENTER, QUALITY INSPECTION TEAM

健全的客户服务体系
SOUND CUSTOMER SERVICE NETWORK