

# Small, compact Thermostat SKTO 011 / SKTS 011



- 设定范围广
- 体积小
- 便于安装
- 高切换性能

**SKTO 011:** 恒温器 (常闭); 断路器调节加热器.

**SKTS 011:** 恒温器 (常开); 接触器调节过滤风扇和热交换或温度超限时切换到信号装置.



### Technical Data

切换温差	7K (± 4K公差)
感应元件	双金属感温材料
接触型态	单元动态连接
接触电阻	< 10mΩ
服务寿命	> 100 000 周期
最大交换容量	250VAC, 10 (2) A 120VAC, 15 (2) A
电磁兼容性	DC 30W acc. to EN 55014-1-2, EN 61000-3-2, EN 61000-3-3
连接	2极端子台, 夹紧最大扭矩0.5Nm 钢性线2.5mm <sup>2</sup>
安装	钢绞线(线端带铁包) 1.5mm <sup>2</sup> 35mm DIN导轨卡装 (EN50022)
外壳	(or for exit filter EF 118 Series) UL94 V-0浅灰色塑料
尺寸	60 x 33 x 43mm
重量	约 40g
固定位置	不限
适应温度	-45 to +80°C (-49 to +176°F)
保护等级	IP20

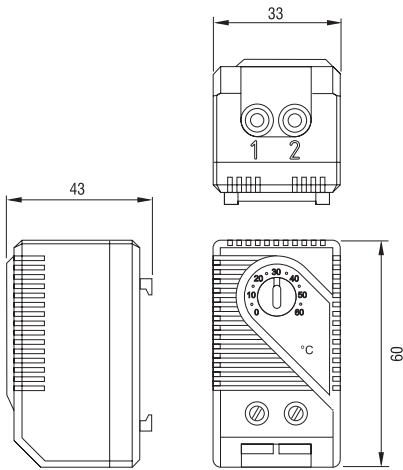

温控器  
SKTO 011 (NC)

温控器  
SKTS 011 (NO)

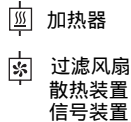
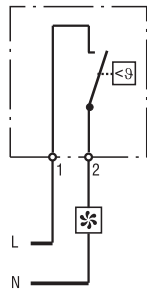
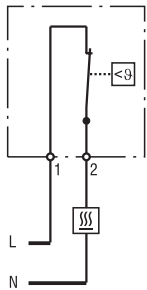

连接实例

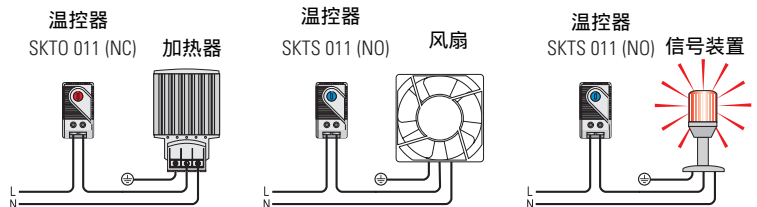

连接实例

设置范围	断路器型号	接触器型号	
0 to +60°C	01140.0-00	01141.0-00	
-10 to +50°C	01142.0-00	01143.0-00	
+20 to +80°C	01159.0-00	01158.0-00	
+32 to +140°F	01140.9-00	01141.9-00	
+14 to +122°F	01142.9-00	01143.9-00	
0 to +60°C	01146.9-00	01147.9-00	